

Service  
Service  
**Service**



# Service Manual

## TABLE OF CONTENTS

	Page
Technical Specifications .....	1-2
Measurement setup .....	1-3
Service Aids, Safety Instruction, etc. ....	1-4 to 1-5
Lead-free Information & Service Instruction .....	1-6 to 1-7
Installation & Preparations & Controls .....	1-8 to 1-15
Troubleshooting .....	1-15 to 1-16
Disassembly Instructions & Service positions .....	2
Service Test Programs .....	3
Set Block diagram .....	4
Set Wiring diagram .....	5
Display Board & AMP Key Board .....	6
Tuner Board .....	7
Power Board .....	8
Woofer Output Board .....	9
Scart Board .....	10
Set Mechanical Exploded View & Parts List .....	11
Electrical Parts List .....	12
Revision List .....	13



© Copyright 2009 Philips Consumer Electronics B.V. Eindhoven, The Netherlands  
 All rights reserved. No part of this publication may be reproduced, stored in a retrieval system or transmitted, in any form or by any means, electronic, mechanical, photocopying, or otherwise without the prior permission of Philips.

Published by SL 0910 Service Audio

Printed in The Netherlands

Subject to modification



3141 785 30806

Version 1.6



# PHILIPS



## SPECIFICATION

### GENERAL:

Mains voltage : 230V  $\pm$  10% /12 , 220V  $\pm$  10% /93  
 120V  $\pm$  10% / 230V  $\pm$  10% /55/96/98  
 120V  $\pm$  10% /37  
 Mains frequency : 50/60Hz /55/96/98  
 : 50Hz /12/93  
 : 60Hz /37  
 Power consumption : < 1W at ECO Standby /12/37  
 < 4W Standby w/Clock on  
 < 35W Active  
 Clock accuracy : < 2 seconds per day  
 Dimension w/o Boxes : 472(W) x 360(H) x 224(D)mm

### TUNER:

#### FM

Tuning range : 87.5-108MHz  
 Grid : 50kHz/100kHz  
 IF frequency : 10.7MHz  $\pm$  20kHz  
 Aerial input : Pigtail Antenna Wire  
 Sensitivity at 26dB S/N : < 22dBf  
 Selectivity at 300kHz bandwidth : > 33dB  
 S/N Ratio stereo input 80dB : > 55dB  
 IF rejection : > 60dB  
 Image rejection : > 25dB  
 Distortion at RF=1mV, dev. 75kHz : < 3%  
 -3dB Limiting point : < 23.5dBf  
 Adjacent Channel Selectivity : > 33dB  
 Channel Separation -400/1K/5K : 20/26/18dB

### AMPLIFIER:

Output power  
 Mains Operation (Nominal, 6 $\Omega$ , 10% THD)  
 : 2 x 20W  
 Subwoofer Out (8 $\Omega$ , 10% THD)  
 : 2 x 50W  
 Frequency response within  $\pm$ 3dB : 100Hz-15kHz  
 Woofer within -6dB : 50Hz-180Hz  
 S-Bass & Loudness : ON/OFF  
 Digital Sound Control : Classic, Jazz, Rock, Pop or Flat  
 For DVD : Normal, Concert, Drama, Action or SCI-FI  
 Headphone output at 32K $\Omega$  : 700mV  $\pm$  2dB  
 Input sensitivity  
 DVD : -6dB track (Audio Disc1,Trk35)

### COMPACT DISC:

Measurement done at output conn. of the DVD module.  
 Frequency response within  $\pm$  1.0dB: 20Hz - 20kHz  
 Signal/Noise ratio (A-weighted) : > 70dBA  
 Channel Unbalance : <  $\pm$ 2dB (Vol 0 \_-50dB)  
 Channel Separation (1K) : 40dB  
 (16K) : 35dB  
 (20K) : 30dB  
 THD Noise (20-20,000Hz) at 1kHz : 0.5%  
 De-emphasis : 0 or 15/50  $\mu$ S (Switched automatically  
 by CD10)  
 S/N Luminance : > 48dB  
 Video Bandwidth : 6Mhz  
 Chroma/Luminance Delay : < 80ns  
 Burst/Chroma Ratio : 1.0Vpp(+10/-10%)  
 Amplitude Output : < 80ns  
 MPEG 1 Layer 3 (MP3-CD) : MPEG AUDIO  
 MP3-CD Bit Rate : 8-320 kbps  
 MP3-CD Sampling Frequencies : 8k/11.025k/16k/22.05k  
 /32k/44.1k/48k Hz  
 Recording Format : ISO 9660  
 UDF format not  
 supported

### USB:

Measurement done at speaker terminals across 6 $\Omega$  load  
 w/ 500mW output and DSC setting in Jazz Mode.  
 Frequency response within  $\pm$  3dB : 100Hz - 16kHz  
 Signal/Noise ratio (A-weighted) : > 60dBA  
 Channel crosstalk at 1kHz : > 35dB  
 Channel unbalance at 1kHz :  $\pm$ 3dB

## INFORMATION ABOUT LEAD-FREE SOLDERING

Philips CE is producing lead-free sets from 1.1.2005 onwards.

### IDENTIFICATION:

Regardless of special logo (not always indicated) one must treat all sets from 1 Jan 2005 onwards, according next rules:



### Example S/N:

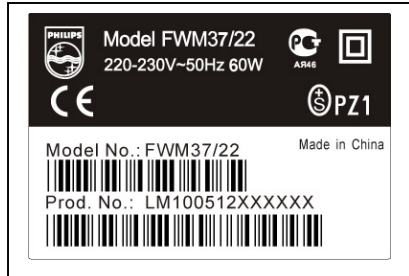

Bottom line of typeplate gives a 14-digit S/N. Digit 5&6 is the year, digit 7&8 is the week number, so in this case 2005 wk12

So from 0501 onwards = from 1 Jan 2005 onwards

**Important note:** In fact also products of year 2004 must be treated in this way as long as you avoid mixing solder-alloys (lead-ed/ lead-free). So best to always use SAC305 and the higher temperatures belong to this.

Due to lead-free technology some rules have to be respected by the workshop during a repair:

- Use only lead-free solder alloy Philips SAC305 with order code 0622 149 00106. If lead-free solder-paste is required, please contact the manufacturer of your solder-equipment. In general use of solder-paste within workshops should be avoided because paste is not easy to store and to handle.
- Use only adequate solder tools applicable for lead-free solder alloy. The solder tool must be able
  - To reach at least a solder-temperature of 400°C,
  - To stabilize the adjusted temperature at the solder-tip
  - To exchange solder-tips for different applications.
- Adjust your solder tool so that a temperature around 360°C – 380°C is reached and stabilized at the solder joint. Heating-time of the solder-joint should not exceed ~ 4 sec. Avoid temperatures above 400°C otherwise wear-out of tips will rise drastically and flux-fluid will be destroyed. To avoid wear-out of tips switch off un-used equipment, or reduce heat.
- Mix of lead-free solder alloy / parts with lead-ed solder alloy / parts is possible but PHILIPS recommends strongly to avoid mixed solder alloy types (lead-ed and lead-free).  
If one cannot avoid or does not know whether product is lead-free, clean carefully the solder-joint from old solder alloy and re-solder with new solder alloy (SAC305).
- Use only original spare-parts listed in the Service-Manuals. Not listed standard-material (commodities) has to be purchased at external companies.
- Special information for BGA-ICs:
  - always use the 12nc-recognizable soldering temperature profile of the specific BGA (for de-soldering always use the lead-free temperature profile, in case of doubt)
  - lead free BGA-ICs will be delivered in so-called 'dry-packaging' (sealed pack including a silica gel pack) to protect the IC against moisture. After opening, dependent of MSL-level seen on indicator-label in the bag, the BGA-IC possibly still has to be baked dry. (MSL=Moisture Sensitivity Level). This will be communicated via AYS-website.
  - Do not re-use BGAs at all.
- For sets produced before 1.1.2005 (except products of 2004), containing lead-ed solder-alloy and components, all needed spare-parts will be available till the end of the service-period. For repair of such sets nothing changes.
- On our website [www.atyourservice.ce.Philips.com](http://www.atyourservice.ce.Philips.com) you find more information to:
  - \* BGA-de-/soldering (+ baking instructions)
  - \* Heating-profiles of BGAs and other ICs used in Philips-sets

You will find this and more technical information within the "magazine", chapter "workshop news".

For additional questions please contact your local repair-helpdesk.

## SERVICE INSTRUCTION

Safety regulations require that after a repair, the set must be returned in its original condition. Pay in particular attention to the following points:

- Route the wire trees correctly and fix them with the mounted cable clamps.
- Check the insulation of the AC Power lead for external damage.
- Check the strain relief of the AC Power cord for proper function.
- Check the electrical DC resistance between the AC Power Plug and the secondary side (only for sets which have a AC Power isolated power supply):
  1. Unplug the AC Power cord and connect a wire between the two pins of the AC Power plug.
  2. Set the AC Power switch to the "on" position (keep the AC Power cord unplugged!).
  3. Measure the resistance value between the pins of the AC Power plug and the metal shielding of the tuner or the aerial connection on the set. The reading should be larger than 4.5 Mohm (For U.S. it should be between 4.2 Mohm and 12 Mohm).
  4. Switch "off" the set, and remove the wire between the two pins of the AC Power plug.
- Check the cabinet for defects, to avoid touching of any inner parts by the customer.

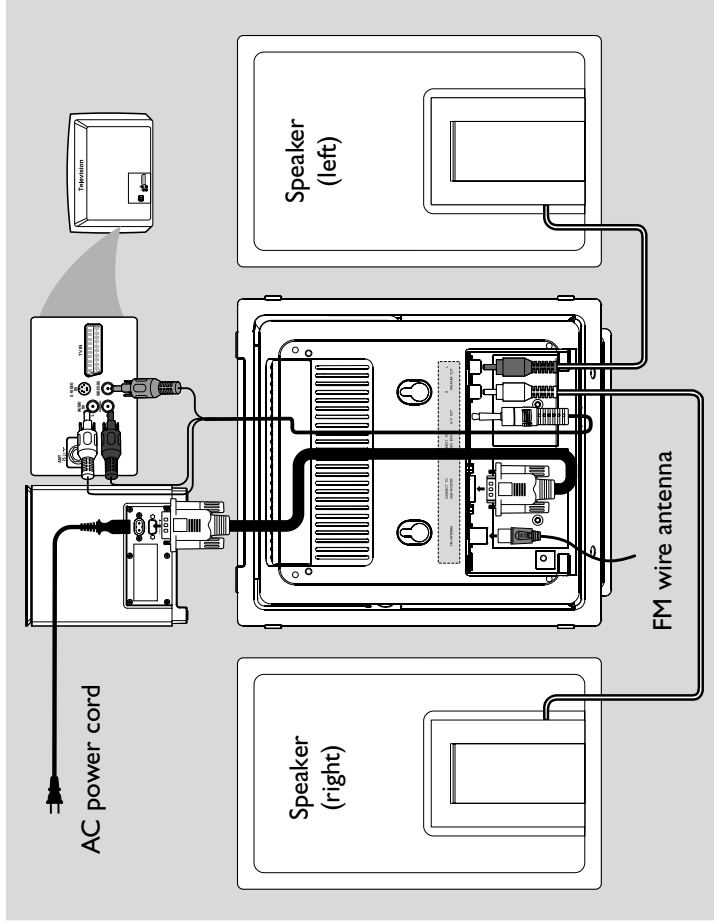

**IMPORTANT!**

- The type plate is located at the rear of the system.
- Before connecting the AC power cord to the wall outlet, ensure that all other connections have been made.
- Never make or change any connections with the power switched on.
- High voltage! Do not open. You run the risk of getting an electric shock.
- The machine does not contain any user-serviceable parts.
- Modification of the product could result in hazardous radiation of EMC or other unsafe operation.

To avoid overheating of the system, a safety circuit has been built in. Therefore, your system may switch to Standby mode automatically under extreme conditions. If this happens, let the system cool down before reusing it (not available for all versions).

**Note:**

- Before installation is finished, it is not recommended to remove the protective plastic film attached to the surface of the front panel to avoid any scratch caused during installation.

**Step 1: Connecting speakers**

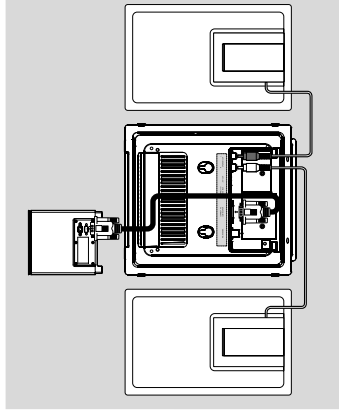

- 1 Place the main set with the front side facing down on a flat and firm surface. Then remove the detachable cover on the back of the set to expose the terminals available for connection.
- 2 Connect the two front speaker cables to the **SPEAKER OUT** terminals: right speaker to "R" and left speaker to "L".
- 3 Connect one end of the 15-pin D-Sub cable (the other end is fixed on the **CONNECT TO SUBWOOFER** terminal on the back of the main set) to the **CONNECT TO MAIN** terminal of the subwoofer by matching the pins. Fix the two screws on the connectors to ensure firm connection.

**Notes:**

- Ensure that the speaker cables are correctly connected. Improper connections may damage the system due to short-circuit.
- For optimal sound performance, use the supplied speakers.
- Do not connect more than one speaker to any one pair of +/- speaker terminals.
- Do not connect speakers with an impedance lower than the speakers supplied. Please refer to the SPECIFICATIONS section of this manual.

**Step 2: FM antenna connection**

Connect the supplied FM antenna to the **FM AERIAL** terminal. Fully extend and adjust the position of the antenna for optimal reception.

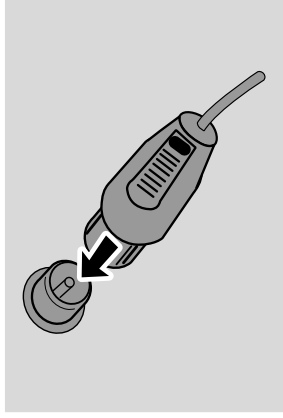

For better FM stereo reception, connect an outdoor FM antenna to the **FM AERIAL (FM ANTENNA)** terminal.

**Notes:**

- This system does not support MW reception.

# Installation

## Step 3: Connecting TV

### IMPORTANT!

- You only need to make one video connection from the following options, depending on the capabilities of your TV.
- Connect the DVD system directly to the TV.

### Using AV OUT jack

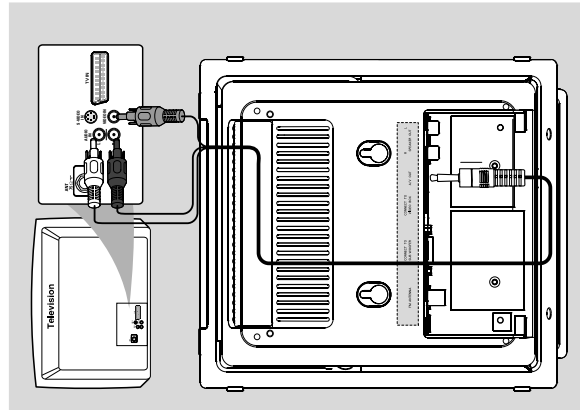

1 Connect the end of the supplied AV cord with only one connector to the **AV OUT** jack of the DVD system.

2 For the other end, connect the video output connector (yellow) to the video input jack (or labeled as A/V In, CV/BS, Composite or Baseband) on the TV. To hear the sound of this DVD system through your TV, connect the audio connectors (white/red) to the audio input jacks on the TV.

### Using the video box

### IMPORTANT!

- A **SCART** connection will let you use features both **Audio** and **Video** on the DVD Player.

The supplied video box provides you with more TV connection options.

First connect the 9-pin connector of the supplied video box to the **CONNECTO VIDEO BOX** jack on the back of the set by matching the pins.

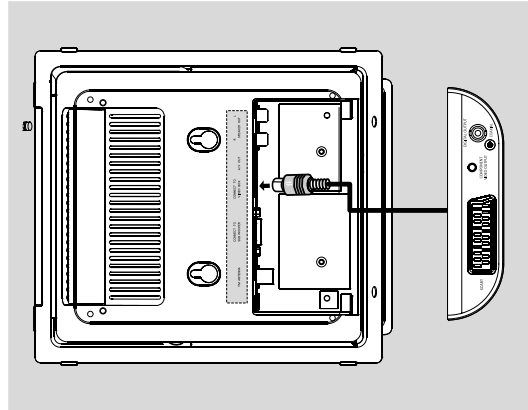

# Installation

### Using SCART jack

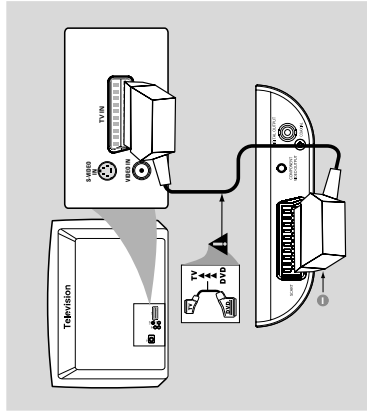

Use the SCART cable (black) to connect the DVD Player's SCART jack (**SCART**) to the corresponding Scart input jacks on the TV.

### Note:

- Ensure that the "TV" indication on SCART cable is connected to the TV set and "DVD" indication on SCART cable is connected to the DVD Player.

### Using Component Video jacks (Y Pb Pr)

### IMPORTANT!

- The progressive scan video quality is only possible when using Y Pb Pr, and a progressive scan TV is required.

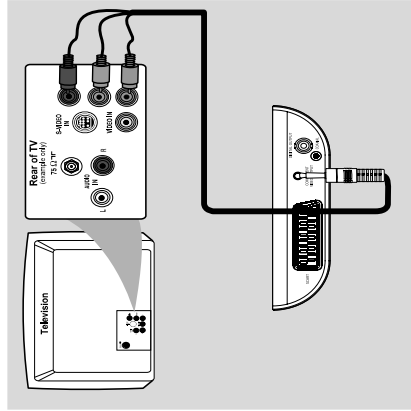

1 Use component video cables (red/blue/green) to connect the **COMPONENT VIDEO OUTPUT (Pr/Cr, Pb/Cb, Y)** jack to the corresponding Component video input jacks (or labeled as Y Pb/Cb Pr/Cr or YUV) on the TV.

2 If you are using a Progressive Scan TV (TV must indicate Progressive Scan or ProScan capability), to activate TV Progressive Scan, please refer to your TV user manual. For DVD system Progressive Scan function, see "Preparations-Setting up Progressive Scan feature".

### Note:

- If your TV does not support Progressive Scan, you will not be able to view the picture. Press **SYSTEM MENU** on the remote to exit the system menu and then **DISC** to exit progressive scan.

## Step 4: Placing the set and speakers

- 1 After finishing all rear connections, mount the detachable cover on the back of the set until hearing a click to avoid cable clutter.

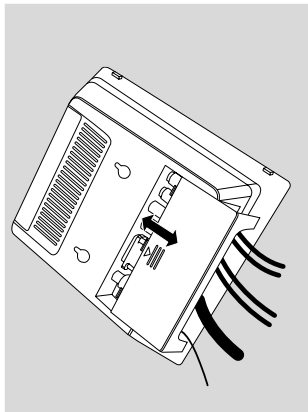

- 2 Align the side marked **PRESS** of the stand to the slots at the bottom of the set.

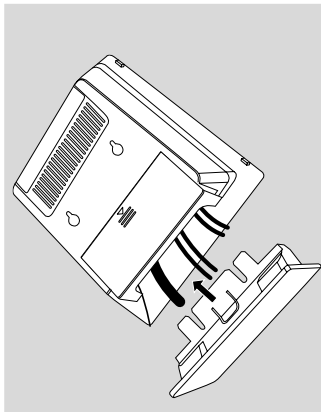

- 3 Push the stand down into the slots until you hear a click.
- 4 Place the set upright on the desktop with the support of the stand.
- 5 Extend the bracket on the back of each front speaker as shown so that the front speakers can stand firmly on the desktop.
- 6 Place the subwoofer on the floor near an AC outlet.

**Note:**

- To remove the stand from the set, while pressing down **PRESS**, pull the stand out from the slots.

## Step 5: Connecting the power cord

After everything is connected properly, plug in the AC power cord to the power outlet.

Never make or change any connection with the power switched on.

## Optional: Connecting additional equipment

### Listening to the playback of a non-USB device

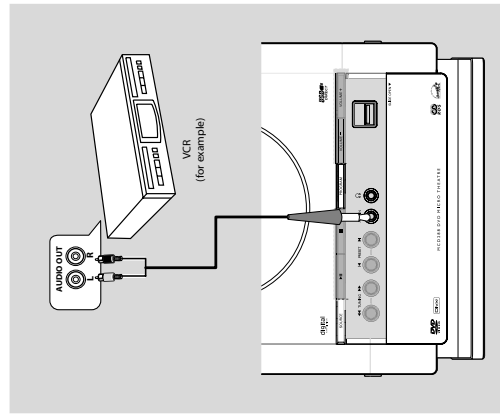

Connect the system's **AUX-IN** jack to the **AUDIO OUT** jacks on another audio/visual device (such as a VCR, Laser Disc player or cassette deck) using a "single-to-double" cinch cable (with one end providing a 3.5" connector for connection to the **AUX-IN** jack while the other end providing two white/red connectors for connection to the other device's **AUDIO OUT** jacks).

## Recording (digital)

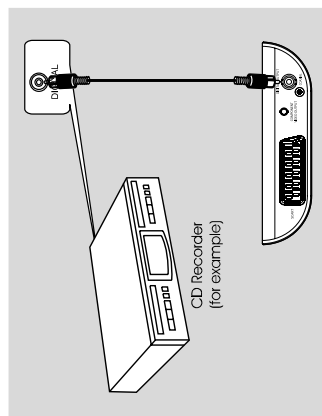

Connect the **COAXIAL (DIGITAL OUTPUT)** jack on the video box to the **DIGITAL IN** jack on a digital recording device (such as DTS Digital Theatre compatible, with Dolby Digital decoder). Before starting operation, set the **DIGITAL OUT** according to the audio connection. (See "DIGITAL OUT".)

## Using the VCR for recording DVDs

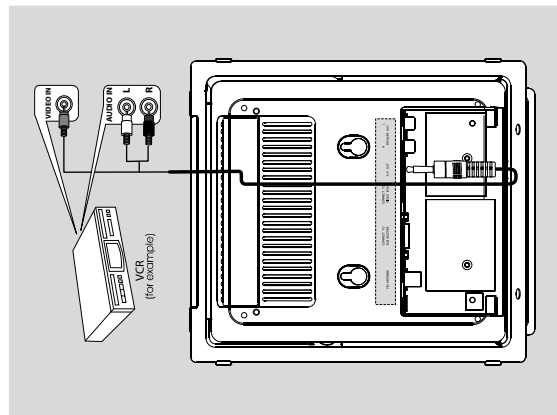

- 1 Connect the end of the supplied AV cord with only one connector to the **AV OUT** jack of the DVD system.
- 2 For the other end, connect the video output connector (yellow) to the **VIDEO IN** jack on the VCR and the audio connectors (white/red) to the corresponding audio input jacks on the VCR. This will allow you to make analogue stereo (two channel, right and left) recordings.

## Installation

### Connecting a USB device or memory card

#### IMPORTANT!

- Before connecting the USB plug, first slide down the movable baffle as shown on Page 3 to expose the  jack.

By connecting a USB mass storage device (including USB flash memory, USB flash players or memory cards) to the Hi-Fi system, you can enjoy the device's stored music through the powerful speakers of Hi-Fi system.

Insert the USB device's USB plug into the  socket on the set.

#### for the devices with USB cables:

- 1 Insert one plug of the USB cable (not supplied) to the  socket on the set.
- 2 Insert the other plug of the USB cable to the USB output terminal of the USB device.

#### for the memory card:

- 1 Insert the memory card into a card reader (not supplied).
- 2 Use a USB cable (not supplied) to connect the card reader into the  socket on the set.



# PREPARATIONS

## Preparations

### IMPORTANT!

- Make sure to complete the preparation procedures before operating the system.

### Step 1: Inserting batteries into the Remote Control

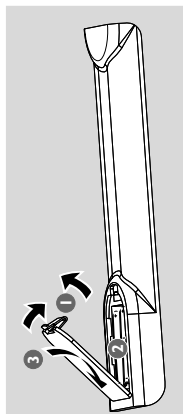

- 1 Open the battery compartment.
- 2 Insert two AAA batteries following the indications (+/-) inside the compartment.
- 3 Close the cover.

### Using the Remote Control to operate the Player

- 1 Aim the Remote Control directly at the remote sensor (IR) on the front panel.
- 2 Do not put any objects between the Remote Control and the DVD Player while operating the DVD Player:

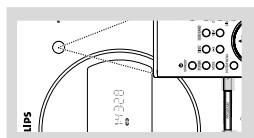

### CAUTION!

- Remove batteries if they are exhausted or if the Remote Control is not being used for a long time.
- Do not use old and new or different types of batteries in combination.
- Batteries contain chemical substances, so they should be disposed of properly.

## Preparations

### Step 2: Setting the clock

- 1 Go to Standby mode.
- 2 Press and hold **CLOCK/RDS** on the remote. "CLK" "SE" "T" is displayed briefly. Then, the hour digits flash on the display screen.
- 3 Press **VOLUME +/- (VOL +/-)** on the remote to set the hours.
- 4 Press **CLOCK/RDS** again. The minute digits flash on the display screen.
- 5 Press **VOLUME +/- (VOL +/-)** on the remote to set the minutes.
- 6 Press **CLOCK/RDS** to confirm the clock setting.

#### Notes:

- This system only supports 24-hour mode.
- The clock setting will be erased when the system is disconnected from the power supply.
- The system will exit clock setting mode if no button is pressed within 30 seconds.

## Preparations

### Step 3: Setting video preference

#### IMPORTANT!

- Make sure you have completed all the necessary connections. (See "Connections-Connecting TV".)

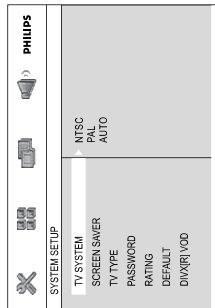

Turn on the TV set and set it to the correct Video-In channel.

You may go to channel 1 on your TV set, then press the channel button repeatedly until you see the Video In channel.

Or, you can use the TV remote control to select different video modes.

Or, set TV to channel 3 or 4 if you are using an RF modulator.

- 1 In stop mode or during playback, press

#### SYSTEM MENU

- 2 Press **◀/▶/▲/▼** on the remote control to toggle through the functions and select your preferential option.

- Move to **SYSTEM SETUP** and press **▼**.
- Move to one of the following and press **▶**.

#### Setting TV SYSTEM

Allows you to select the colour system matching the connected TV set.

#### NTSC

- If the connected TV is NTSC system, select this mode. It will change the video signal of a PAL disc and output in NTSC format.

#### PAL

- If the connected TV is PAL system, select this mode. It will change the video signal of a NTSC disc and output in PAL format.

#### AUTO

- If the connected TV is multi system, select this mode. The output format will be in accordance with the video signal of the disc.

#### Setting TV TYPE

Select the aspect ratio of the TV to be connected.

#### 4:3 PS (Pan and Scan mode)

- If you have a conventional TV set and your DVD is not formatted for widescreen viewing, use this setting. A wide picture is displayed on the whole TV screen with a portion automatically cut off.

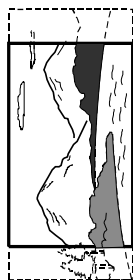

#### 4:3 LB (Letterbox mode)

- If you have a conventional TV set and your DVD is formatted for widescreen viewing, use this setting. A wide picture with bands displayed on the upper and lower portions of the TV screen.



#### 16:9 (Wide screen mode)

- If you have a widescreen TV set, use this setting (you must also set your widescreen TV to "full size") available on a disc, then the disc's own preference will be used.

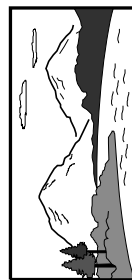

#### Note:

The format you select must be available on the disc. If it is not, the setting for TV Type will not affect the picture during playback.

#### To exit the menu

Press **SYSTEM MENU** again.

# Preparations

## Setting up Progressive Scan feature (for Progressive Scan TV only)

The progressive scan display twice the number of frames per seconds than interlaced scanning (ordinary normal TV system). With nearly double the number of lines, progressive scan offers higher picture resolution and quality.

### IMPORTANT!

**Before enabling the progressive scan feature, you must ensure:**

- 1) Your TV can accept progressive signals, a progressive scan TV is required.
- 2) You have connected the DVD player to your TV using Y Pb Pr (see "Installation-Step 3: Connecting TV- Using Component Video jacks".)

- 1 Turn on your TV.
- 2 Turn off your TV progressive scan mode or turn on interlaced mode (refer to your TV user manual).

- 3 Press **STANDBY-ON** ( **STANDBY** ) on the remote) to turn on the DVD player:

- 4 Select the correct Video Input channel.  
The DVD background screen appears on the TV.

- 5 Press **SYSTEM MENU**.
- 6 Press **▶** repeatedly to select "**VIDEO SETUP**".

- 7 Select "**TV MODE**" to "**P-SCAN**", then **OK** to confirm.

The instruction menu appears on the TV.



- 8 Press **◀▶** to highlight **OK** in the menu and press **OK** to confirm.

**There will be a distorted picture on your TV at this state until you turn on the progressive scan mode on your TV.**

- 9 Turn on your TV progressive scan mode (refer to your TV user manual).  
The below menu appears on the TV.



- 0 Press **◀▶** to highlight **OK** in the menu and press **OK** to confirm.  
The setup is complete now and you can start enjoy the high quality picture.

## To deactivate Progressive manually

**When the distorted sign still appears on the TV**, it may be due to the connected TV does not accept progressive signals, and progressive is set by mistake. You must reset the unit to interlace format.

- 1 Turn off your TV progressive scan mode or turn on to interlaced mode (refer to your TV user manual).

- 2 Press **SYSTEM MENU** on the remote to exit the system menu and then **DISC** to exit progressive scan.

The DVD blue background screen will appear.

## Step 4: Setting language preference

You can select your preferred language settings so that this DVD Micro System will automatically switch to the language for you whenever you load a disc. If the language selected is not available on the disc, the language set by default will be used instead. But the menu language of the DVD Micro System cannot be changed once selected.

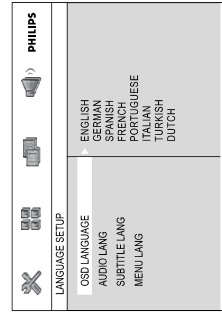

- 1 In stop mode or during playback, press **SYSTEM MENU**.
- 2 Press **◀▶/▲/▼** on the remote control to select your preferred option.

Move to **LANGUAGE SETUP** and press **▼**.  
Move to one of the following and press **▶**.

# PREPARATIONS

## Preparations

### OSD LANGUAGE (On-Screen Display)

Switches the display language on the TV screen. Select the language from the displayed list.

### AUDIO LANG (DVD only)

Switches the display language of the sound track. Select the language from the displayed list.

### SUBTITLE LANG (DVD only)

Switches the display language of the subtitle. Select the language from the displayed list.

### MENU LANG (DVD only)

Select the language for the DVD menu.

When the selected language is not recorded in the DVD, one of the recorded languages will be selected automatically (except for OSD). You can reset all the DVD settings except for Rating.

If the language selected is not available on the disc, the original language designated by each disc will be selected.

- 3 Press **▲/▼** to select a language and press **OK**.
- 4 Repeat **steps 2~3** for other settings.

### To exit the menu

Press **SYSTEM MENU** again.

## CONTROLS

## Controls

- Controls on the system**
- 1 **ECO POWER/STANDBY ON** to switch the system on or to Eco power/normal standby mode.
  - 2 **iR sensor** infrared sensor for remote control.
  - 3 **PROGRAM** DVD/VCD/CD/MP3-CD/USB: enters the program menu.  
Picture CD: during playback, to select a slide show mode.  
Tuner: programs preset radio stations.
  - 4 **Mode Selection** In DISC/USB mode, to stop playback or clear a program.  
for Demo (on the system only) to activate/deactivate the demonstration.  
 In DISC/USB mode, to start or interrupt playback.
  - 5 **PRESET** Disc/USB: skips to the previous/next chapter/title/track.  
Tuner: selects a preset radio station.
  - 6 **TUNING** Tuner  
press to tune to a lower/higher radio frequency gradually.  
press and hold, then release the key to start automatic search for a radio frequency downward/upward.  
Disc/USB  
searches fast backward/forward.
  - 7 **Display screen** to view the current status of the system.
  - 8 **SOURCE** to select the respective sound source: TUNER, DISC, USB/CARD or AUX.
  - 9 **VOLUME +/-** adjusts the volume upward/downward.  
adjusts the hours and minutes in clock/timer setting mode.  
selects a source in timer setting mode.
  - 10 to connect a headphone.
  - 11 **EJECT** ejects a disc from the disc loader.

- 12 **AUX-IN** connects an external non-USB device.
  - 13 **USB DIRECT** jack for the external USB mass storage device.
  - 14 **SLIDE OPEN** slides down to expose some buttons and jacks on the front panel.
- Controls on the remote control**
- 1 **STANDBY** to switch the system on or to Eco power/normal standby mode.
  - 2 **Numeric Keypad (0-9)** inputs a track/title/chapter number of the disc.
  - 3 **PROGRAM** DVD/VCD/CD/MP3-CD/USB: enters the program menu.  
Picture CD: during playback, to select a slide show mode.  
Tuner: programs preset radio stations.
  - 4 **SOURCE** to select the respective sound source: TUNER, DISC, USB/CARD or AUX.
  - 5 **SYSTEM MENU** (disc mode only) to enter or exit the system menu bar.
  - 6 **DISC MENU** (disc mode only) DVD/VCD: enters or exits the disc contents menu.  
VCD2.0: switches the playback control mode on or off.
  - 7 Tuner  
press to tune to a lower/higher radio frequency gradually.  
press and hold, then release the key to start automatic search for a radio frequency downward/upward.  
Disc/USB  
searches fast backward/forward.  
In DISC mode, to select a movement direction in the disc menu or system menu bar.
  - 8 In DISC mode, to select a movement direction in the disc menu or system menu bar.  
selects different slow playback modes for a VCD/SVCD/DVD.

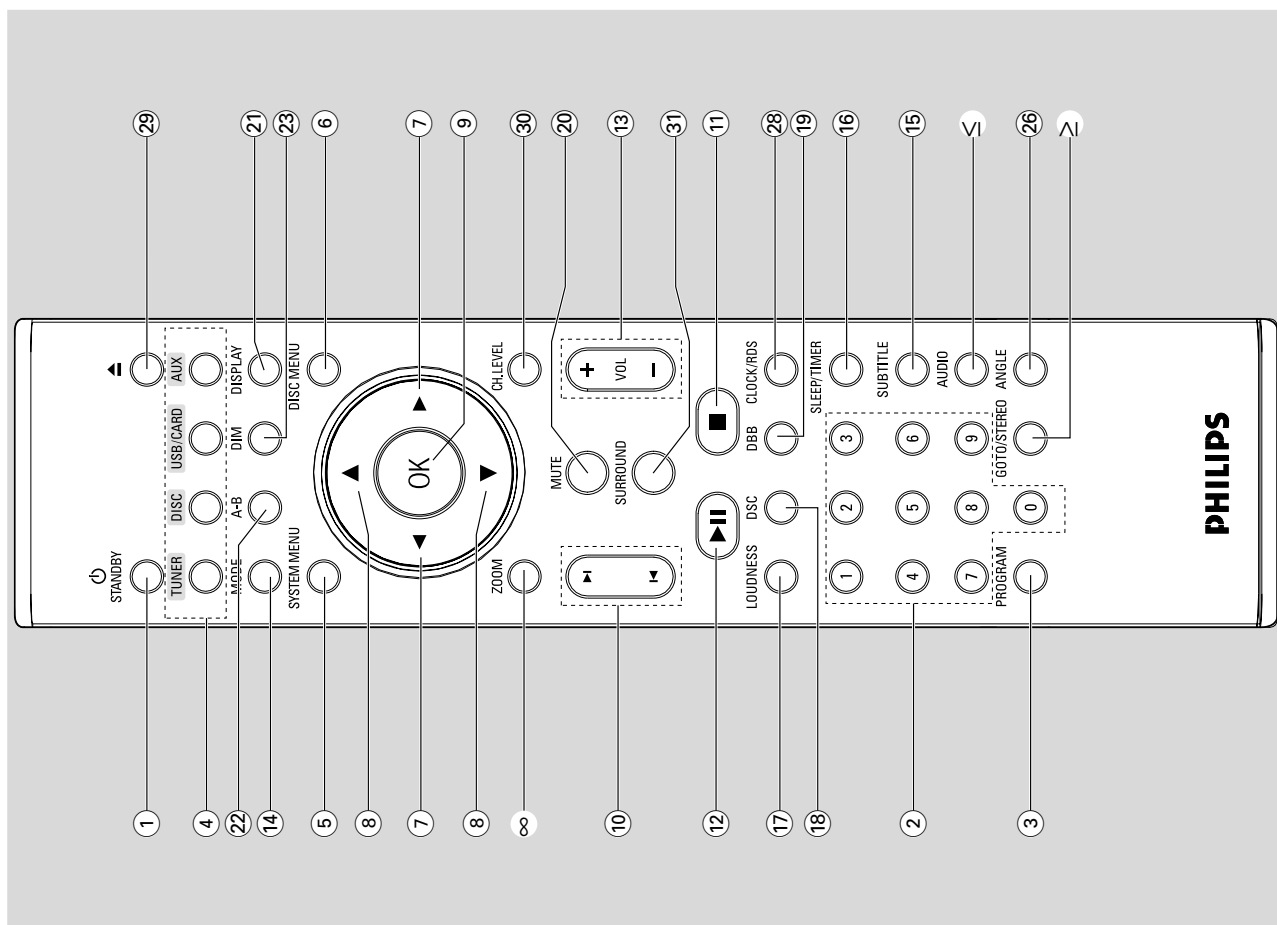

\* = Press and hold the button for more than three seconds.

# CONTROLS & TROUBLESHOOTING

## Controls

- 9 OK**
  - to exit or confirm the selection.
- 10** /
  - Disc: skips to the previous/next chapter/title/track.
  - Tuner: selects a preset radio station.
- 11**
  - In DISC/USB mode, to stop playback or clear a program.
- 12**
  - In DISC/USB mode, to start or interrupt playback.
- 13** VOL +/-
  - adjusts the volume upward/downward.
  - adjusts the hours and minutes in clock/timer setting mode.
  - selects a source in timer setting mode.
- 14** **MODE**
  - selects various repeat modes or the shuffle play mode for a disc.
- 15** **SUBTITLE**
  - selects a subtitle language.
- 16** **SLEEP/TIMER**
  - Standby mode
  - sets time for switching on the system automatically.
- Power-on mode**
  - sets the sleep timer function (auto off).
- 17** **LOUDNESS**
  - enables or disables automatic loudness adjustment.
- 18** **DSC**
  - selects different types of preset sound equalizer settings (CLASSIC, JAZZ, ROCK, POP or FLAT; for DVD: NORMAL, CONCERT, DRAMA, ACTION or SCI-FI).
- 19** **DBB**
  - enables or disables bass enhancement.
- 20** **MUTE**
  - to interrupt or resume sound reproduction.
- 21** **DISPLAY**
  - displays information on TV screen during playback.
- 22** **A-B**
  - for VCD/CD/USB: to repeat a specific section within the same track.
  - for DVD: to repeat a specific section in a disc.
- 23** **DIM**
  - selects different levels of brightness for the display screen.
- AUDIO**
  - sets Stereo, Mono-Left or Mono-Right sound mode.
  - for DVD
    - selects an audio language.
- ∞ ZOOM**
  - DVD/CD/Picture CD: enlarges or reduces a picture or active image on the TV screen.
- 26** **ANGLE**
  - selects a DVD camera angle.
- ≥ GOTO/STEREO**
  - In DISC mode, to fast search in a disc by entering a time, title, chapter or track.
  - FM: sets stereo or mono sound mode.
- 28** **CLOCK/RDS**
  - Standby mode
  - sets the system clock.
  - Playback mode
  - displays the system clock.
  - For tuner
  - displays RDS information.
- 29**
  - ejects a disc from the disc loader.
- 30** **CH.LEVEL (unavailable for this version)**
- 31** **SURROUND (unavailable for this version)**

\* = Press and hold the button for more than three seconds.

## Troubleshooting

### WARNING

Under no circumstances should you try to repair the system yourself, as this will invalidate the warranty. Do not open the system as there is a risk of electric shock.

If a fault occurs, first check the points listed below before taking the system for repair. If you are unable to remedy a problem by following these hints, consult your dealer or Philips for help.

Problem	Solution
<b>No power.</b>	Check if the AC power cord is properly connected. Check if the disc is inserted upside down. Wait until the moisture condensed at the lens has cleared. Replace or clean the disc, see "Maintenance". Use a readable disc or correctly recorded format MP3-CD.
<b>"NO DISC" is displayed.</b>	Select the appropriate video input mode on the TV set. Check if the TV set is switched on. Check the video connection. Check if the system is securely connected. If the progressive scan feature is activated but the connected TV does not support progressive signals or the cables are not connected accordingly see "Preparations-Setting up Progressive Scan feature" for proper progressive scan setup or deactivate the progressive scan feature as below: 1) Turn off your TV progressive scan mode or turn on to interlaced mode. 2) Press SYSTEM on the remote to exit the system menu and then DISC to exit progressive scan.
<b>No picture.</b>	Sometimes a slight picture distortion may appear. This is not a malfunction. Clean the disc. Connect the system to the S-video input of your TV set. The aspect ratio is fixed on the DVD disc. The aspect ratio may not be changed for some TV systems.
<b>Distorted or poor picture.</b>	
<b>The aspect ratio of the screen cannot be changed even though you have set the TV shape.</b>	

Problem	Solution
<b>The DVD player does not start playback.</b>	<p>Insert a readable disc.            Check the disc type, color system and region code.            Clean the disc.            Place the disc with the playback side down.            Press SYSTEM MENU to turn off the setup menu.            Cancel the parental control rating function or change the rating level.            Moisture has condensed inside the system.            Remove the disc and leave the system turned on for about an hour.            Disconnect the power plug from the jack, and insert again.            Multi-language sound or subtitle is not recorded on the DVD.            Changing the language for the sound or subtitle is prohibited on the DVD.</p>
<b>The DVD player does not respond when buttons are pressed.</b>	
<b>The language for the sound or subtitle cannot be changed when playing a DVD.</b>	
<b>No image is output when a function is selected.</b>	<p>Make sure the component is connected correctly.            Press the correct function button for the input source.            Adjust the volume.            Disconnect the headphones.</p>
<b>Sound cannot be heard or is of poor quality</b>	<p>Check that the speakers are connected correctly.            Check if the stripped speaker wire is clamped.            If the system is in pause, slow motion or fast forward/reverse mode, press PLAY/PAUSE ►   to resume the normal play mode.            Make sure the MP3-CD was recorded within 32-256 kbps bit rate with sampling frequencies at 48 kHz, 44.1 kHz or 32 kHz.            Ensure that the DTS disc also supports Dolby Digital output.</p>
<b>Poor radio reception.</b>	<p>If the signal is too weak, adjust the antenna or connect an external antenna for better reception.            Increase the distance between the System and your TV set or VCR.</p>
<b>Recording or playback cannot be made</b>	<p>Clean deck parts, see "Maintenance".            Use only NORMAL tape.            Apply a piece of adhesive tape over the missing tab space.            Check the speaker connections and location.</p>
<b>Left and right sound outputs are reversed.</b>	
<b>The remote control does not function.</b>	<p>Point the remote control at the remote control sensor of the unit.            Reduce the distance to the player.            Remove any possible obstacles.            Replace the batteries with new ones.            Check that the batteries are loaded correctly.</p>
<b>The timer is not working</b>	<p>Set the clock correctly.            If recording is in progress, stop it</p>
<b>The Clock/Timer setting is erased</b>	<p>Power has been interrupted or the power cord has been disconnected. Reset the clock/timer.</p>
<b>No sound and picture</b>	<p>Check that the RGB/SCART cable is connected to the correct device (See Connecting TV).</p>
<b>Some files on the USB device are not displayed.</b>	<p>Check if the number of folders exceeds 99 or the number of titles exceeds 999.</p>

## DISMANTLING INSTRUCTIONS

### *Dismantling of the Front Panel assembly*

- 1) Loosen & remove 4 screws A (see figure 1).
- 2) Place a small flat screw driver in between the front & rear cabinets and roll the screw driver along the joint as shown in figure 2.

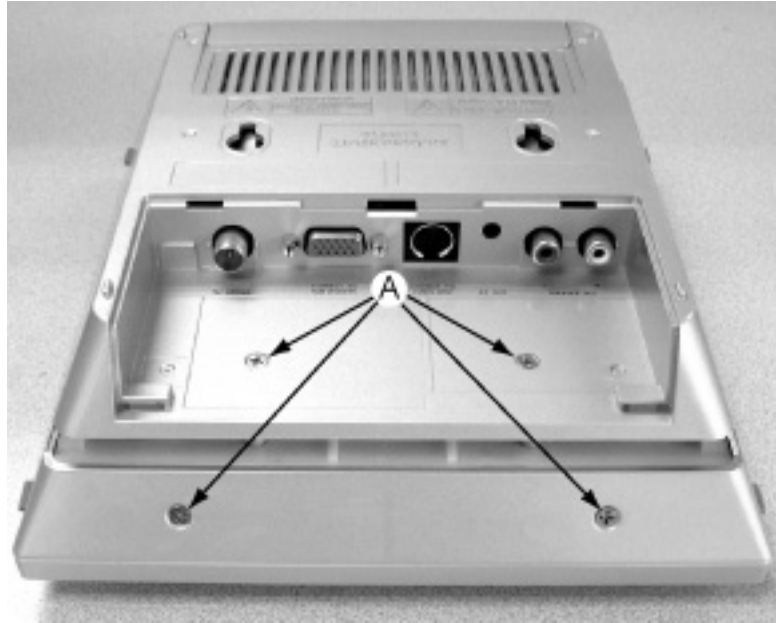

Figure 1

- 3) Release total 6 catches on left and right side of rear cabinet to separate it from the rear assembly.

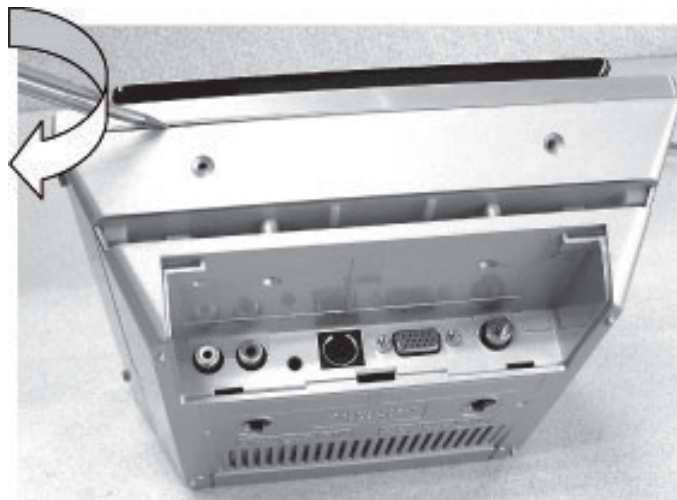

Figure 2

### *Dismantling of the PCB assemblies and modules*

- 1) Loosen 4 screws B to remove DVD Loader as shown in Figure 3.
- 2) Loosen 2 screws C and 7 screws D to remove the Display Board as shown in Figure 4.

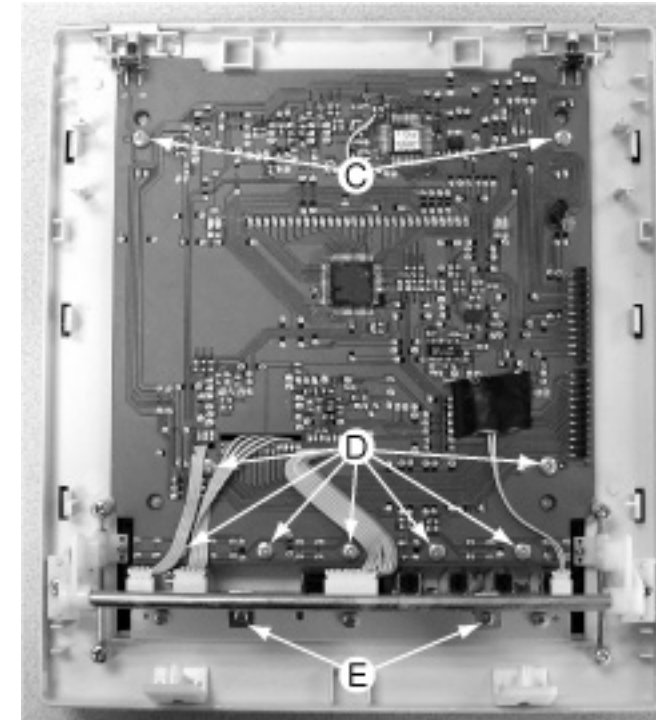

Figure 4



Figure 3

- 3) Loosen 2 screws E to remove the AMP Key Board as shown in Figure 4.

- 4) Loosen 2 screws F and 4 screws G and 2 screws H to remove Swing System as shown in Figure 5.

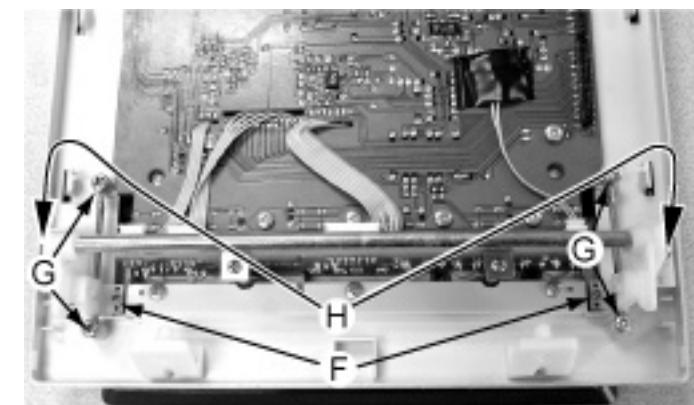

Figure 5

***Dismantling of the PCB assemblies and modules***

- 5) Loosen 3 screws I to remove the Power Board mounting it to the Rear Cabinet as shown in Figure 5.
- 6) Loosen 2 nuts from D-SUB jack on the rear side of the Rear Cabinet to separate it from the Rear panel.

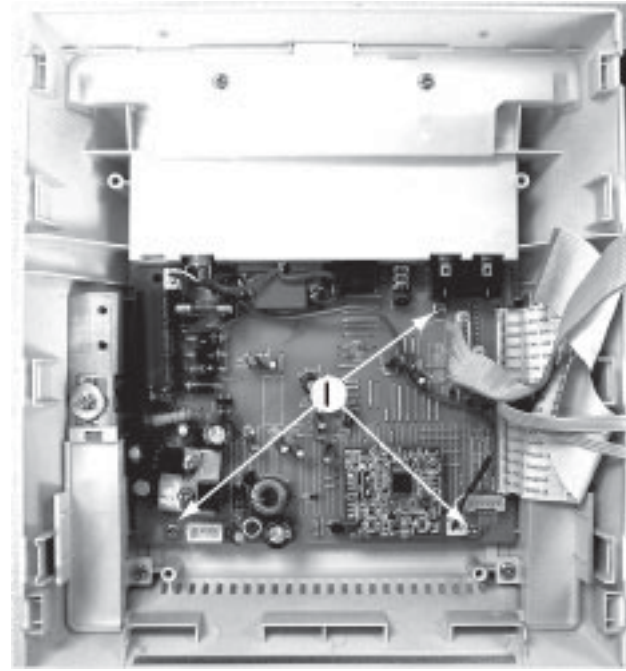

Figure 5

***Dismantling of the Subwoofer***

- 1) Use the flat screw driver prize up 4 rubber pads as shown in Figure 6.
- 2) Loosen 4 screws J to remove two subwoofer feet on the bottom of the subwoofer as shown in Figure 7.

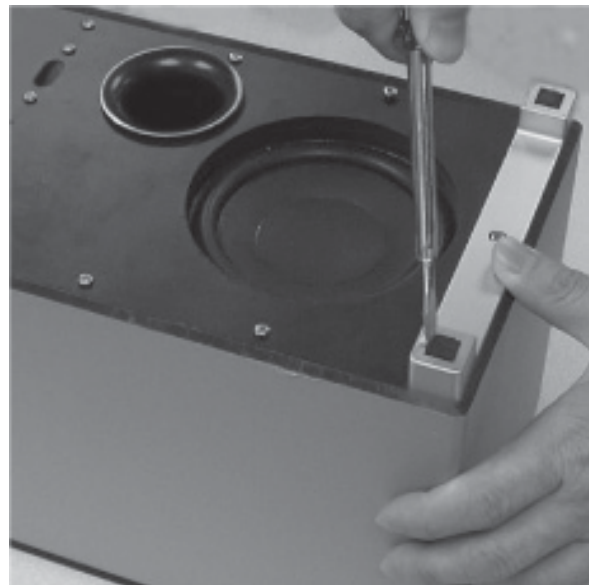

Figure 6

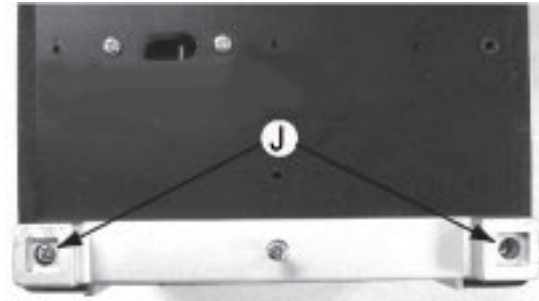

Figure 7

- 3) Loosen 10 screws K to remove the Subwoofer Output Pan as shown in Figure 8.

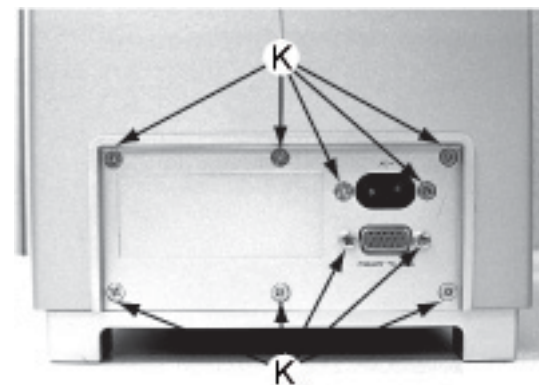
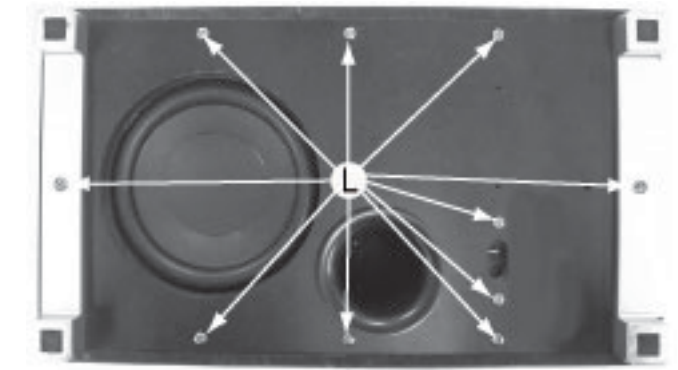

Figure 8

***Dismantling of the Subwoofer***

- 4) Loosen 10 screws L to remove subwoofer bottom cover as shown in Figure 7.



Service pos A

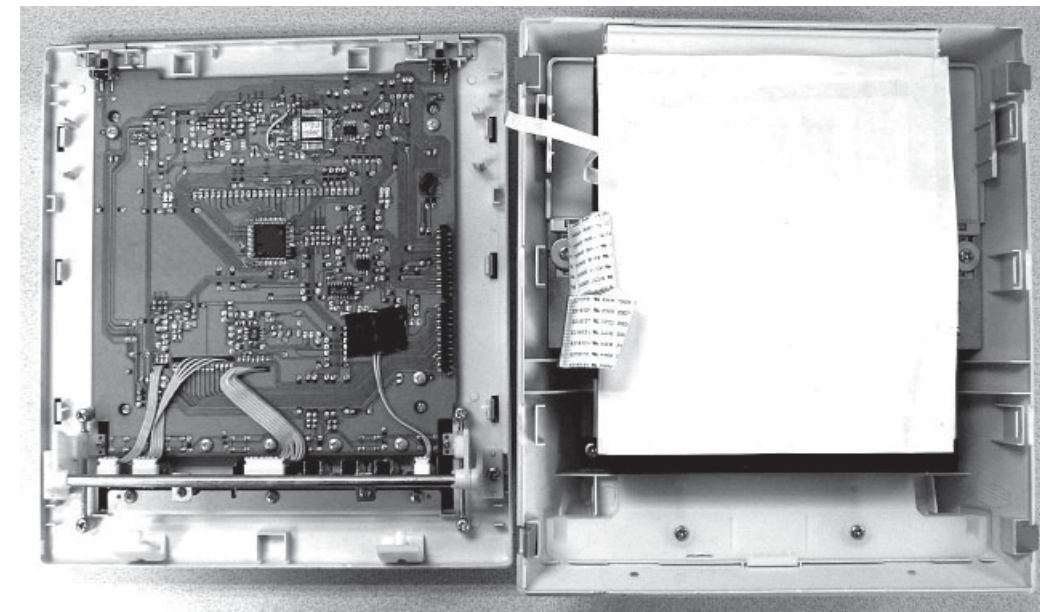

Service pos B

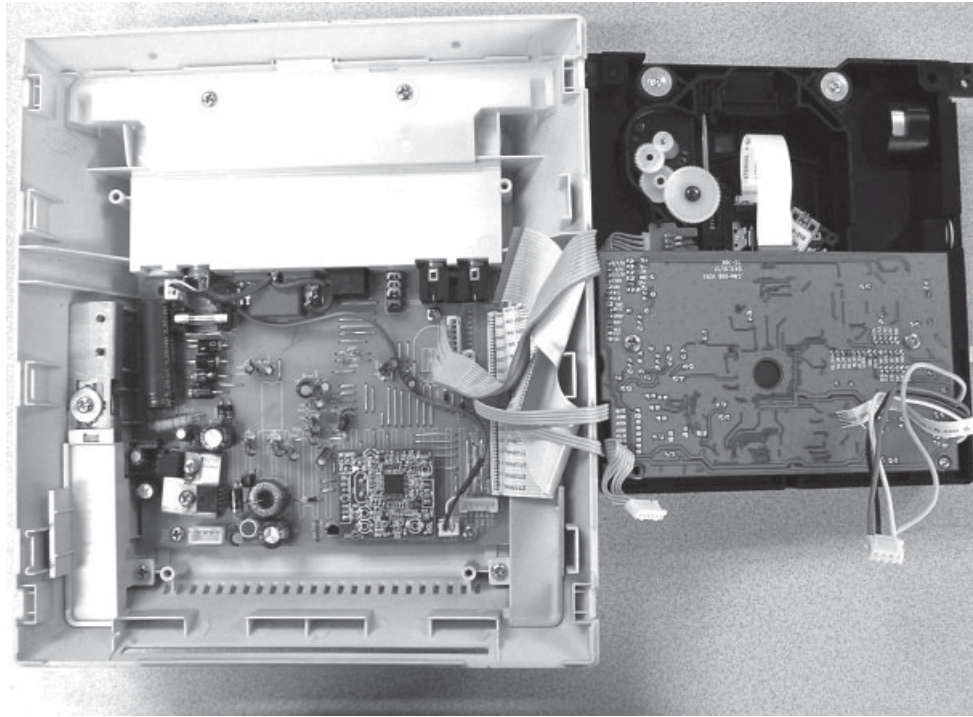

Note: After re-assembly, it is very important to ensure all wires are routed properly to ensure that they do not touch/obstruct all moving parts.

Service pos C

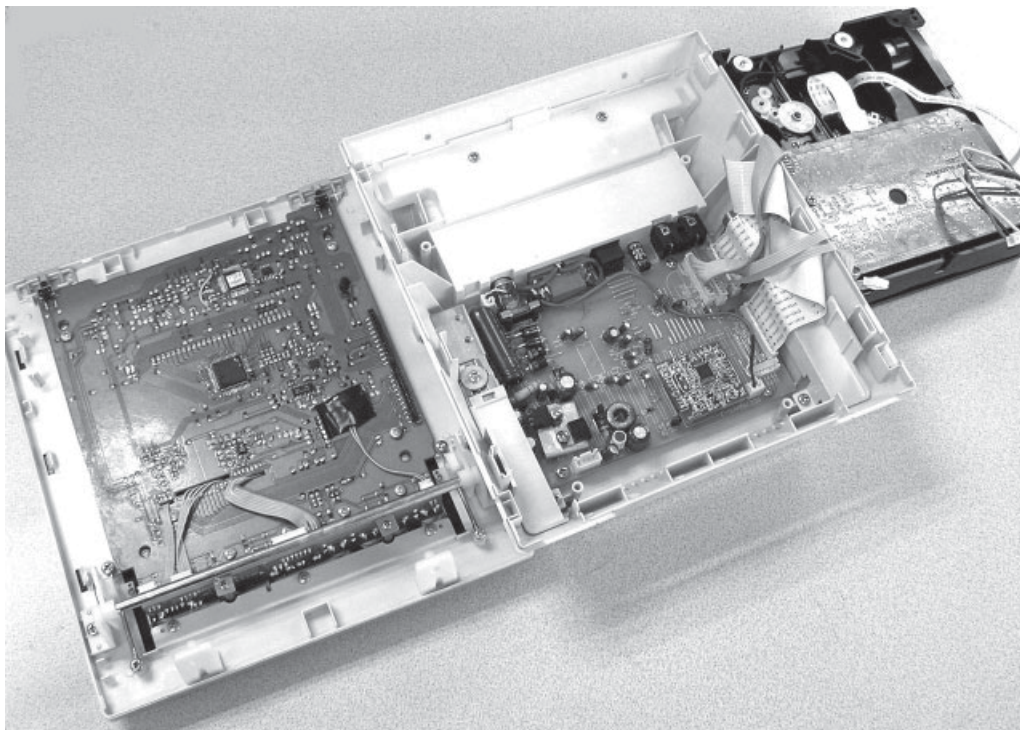



SERVICE TEST PROGRAM

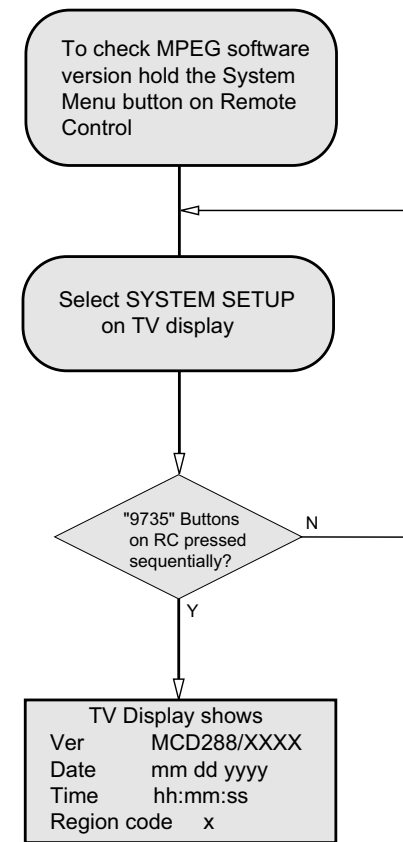
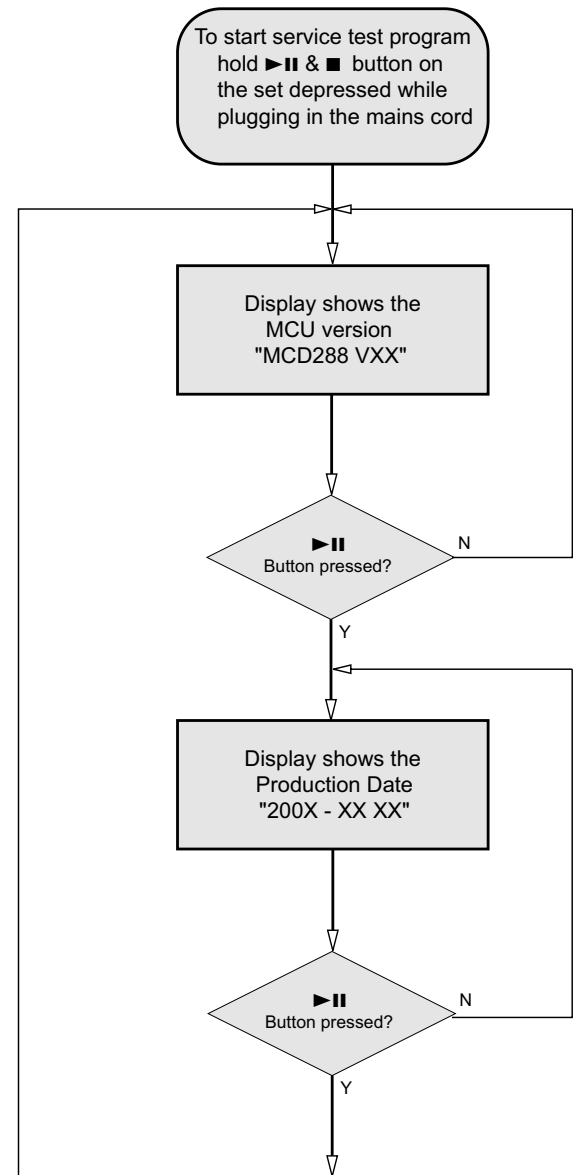

V refers to Version

XX refers to Software version number of the uProcessor  
eg. 04

200X - XX XX refers to Date, eg. 2006-02-22

# SET BLOCK DIAGRAM

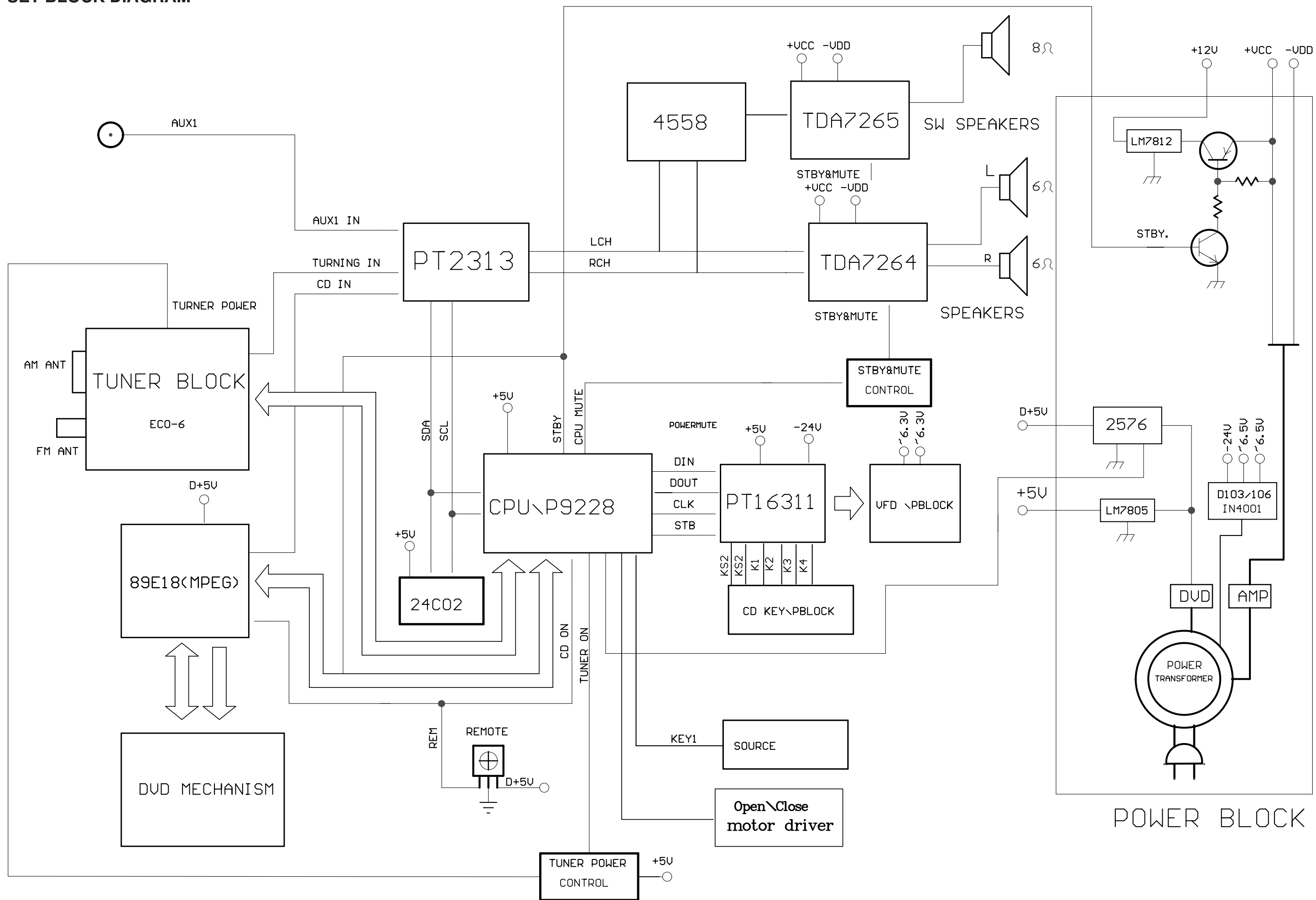

# SET BLOCK DIAGRAM

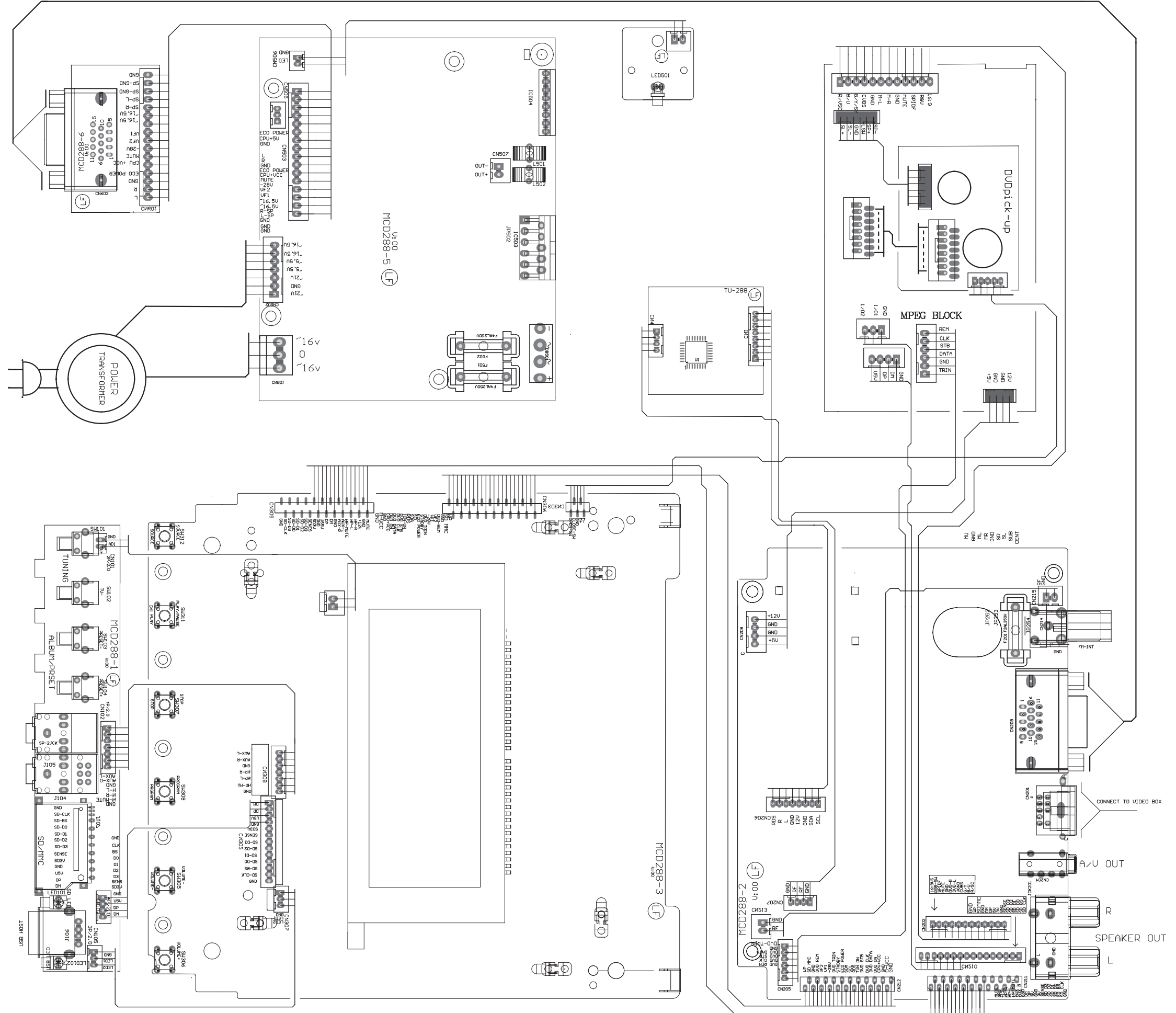

# DISPLAY & AMP KEY BOARD

For Version 37, the board is not intended to be repaired on component level.  
Circuit Diagram and Printed Circuit Board drawings  
are published for orientation only.

In case of defects please replace the entire board.

The Display Board and AMP Key Board can be ordered with codenumber "9940 000 04868" &  
"9940 000 04869" for /37.

## LAYOUT DIAGRAM - AMP KEY BOARD

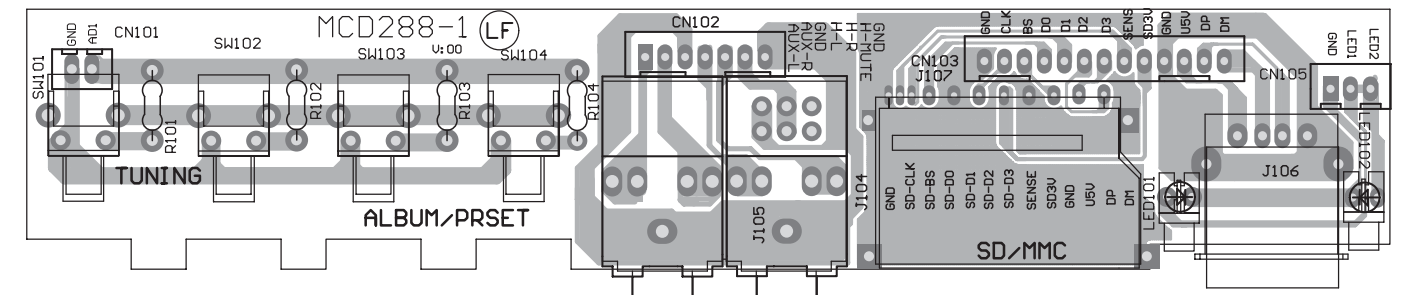

# LAYOUT DIAGRAM - DISPLAY BOARD TOP VIEW

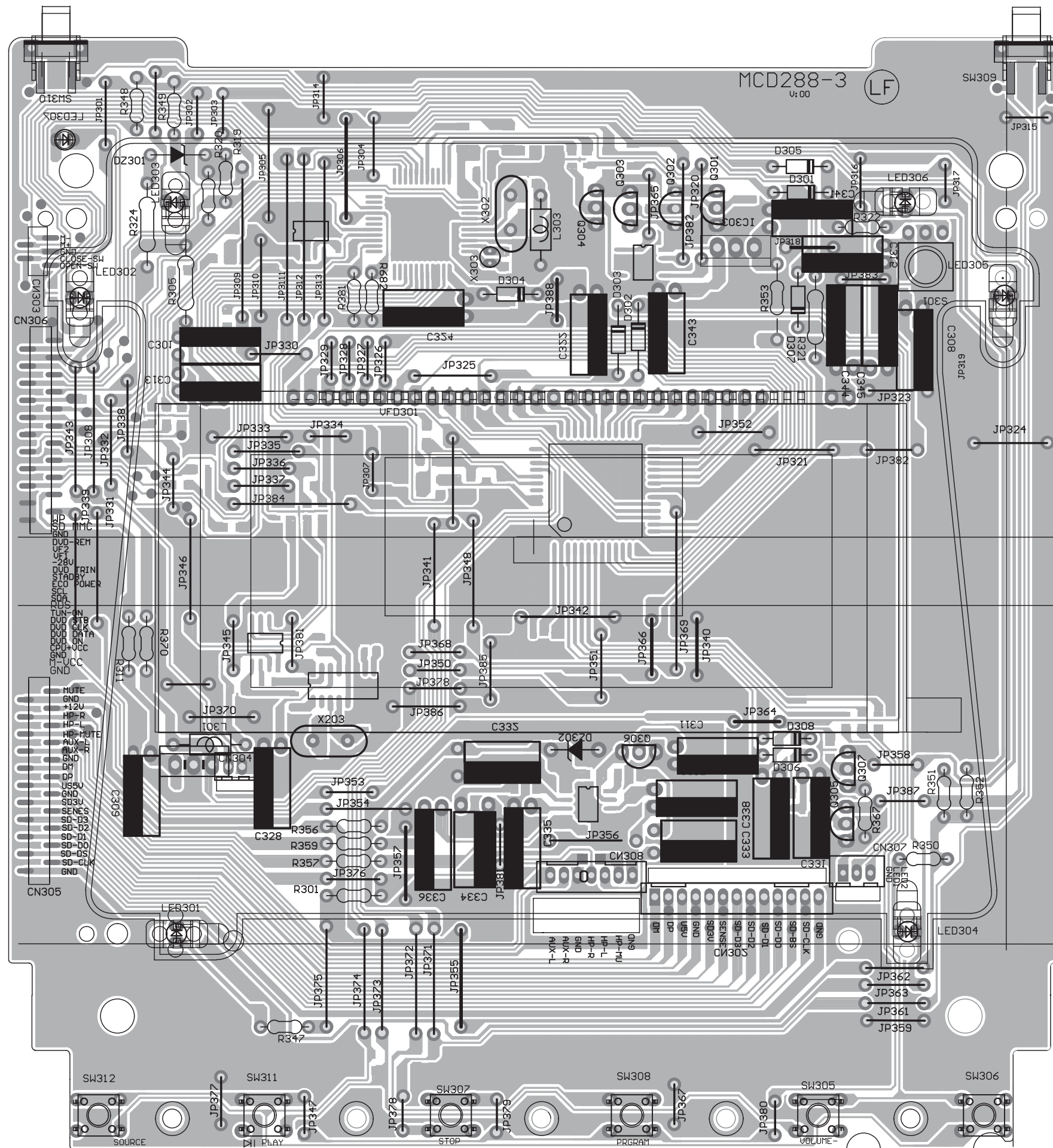

# LAYOUT DIAGRAM - DISPLAY BOARD BOTTOM VIEW

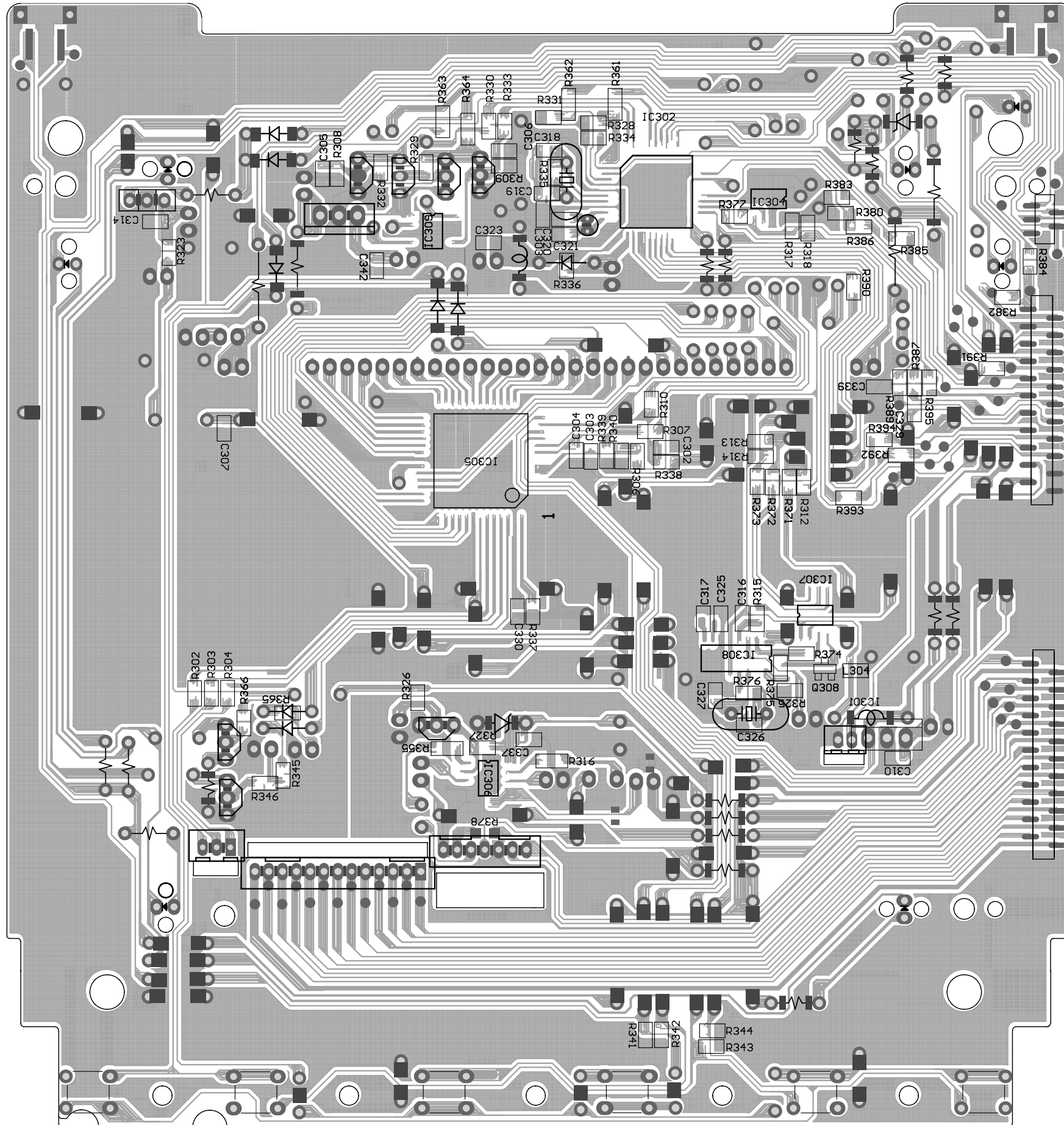

# CIRCUIT DIAGRAM - DISPLAY & KEY BOARD

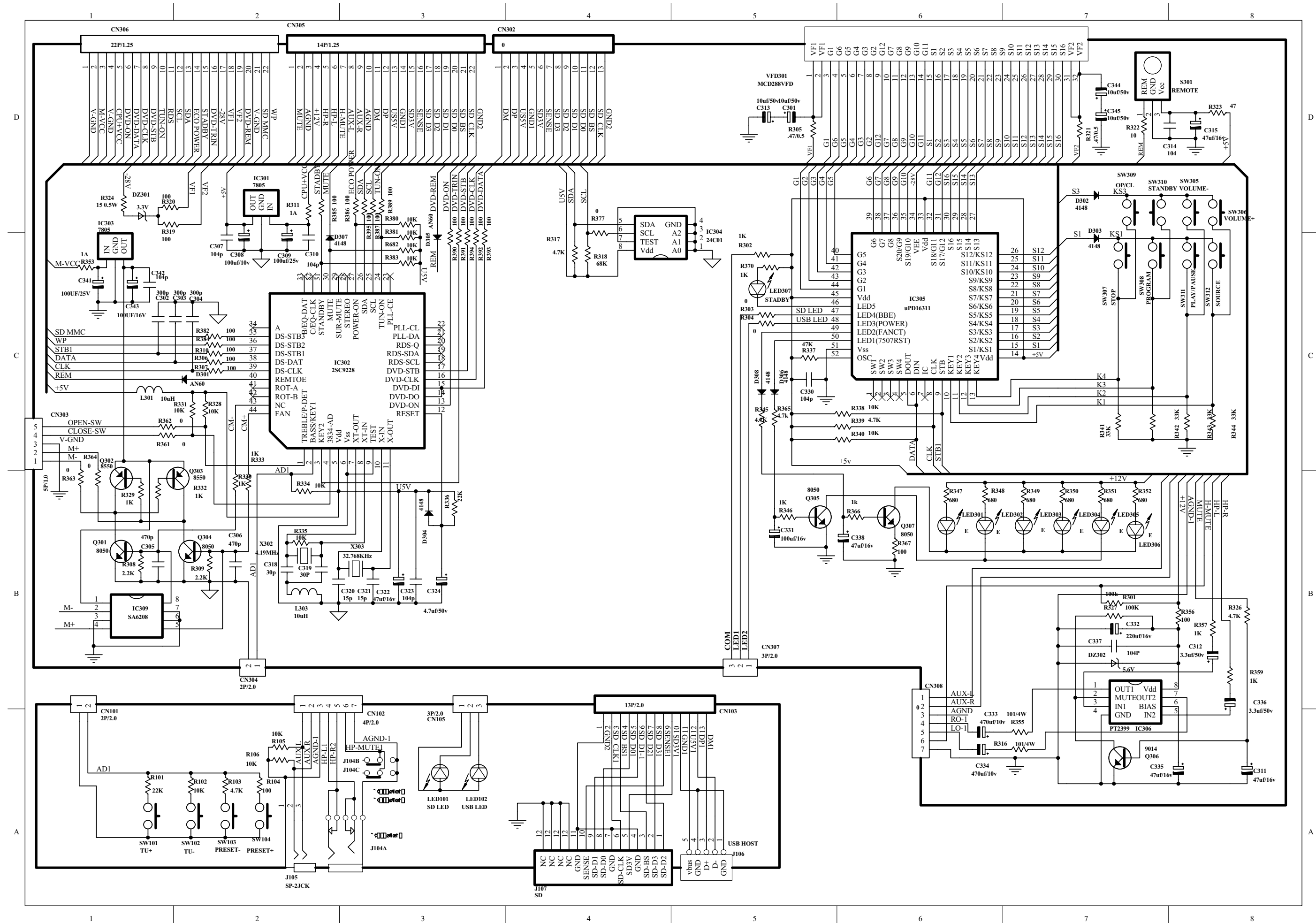

# TUNER BOARD

The board is not intended to be repaired on component level.  
Circuit Diagram and Printed Circuit Board drawings  
are published for orientation only.

In case of defects please replace the entire board.

The board can be ordered with codenumber "9940 000 04875".

## PCB LAYOUT - TOP VIEW

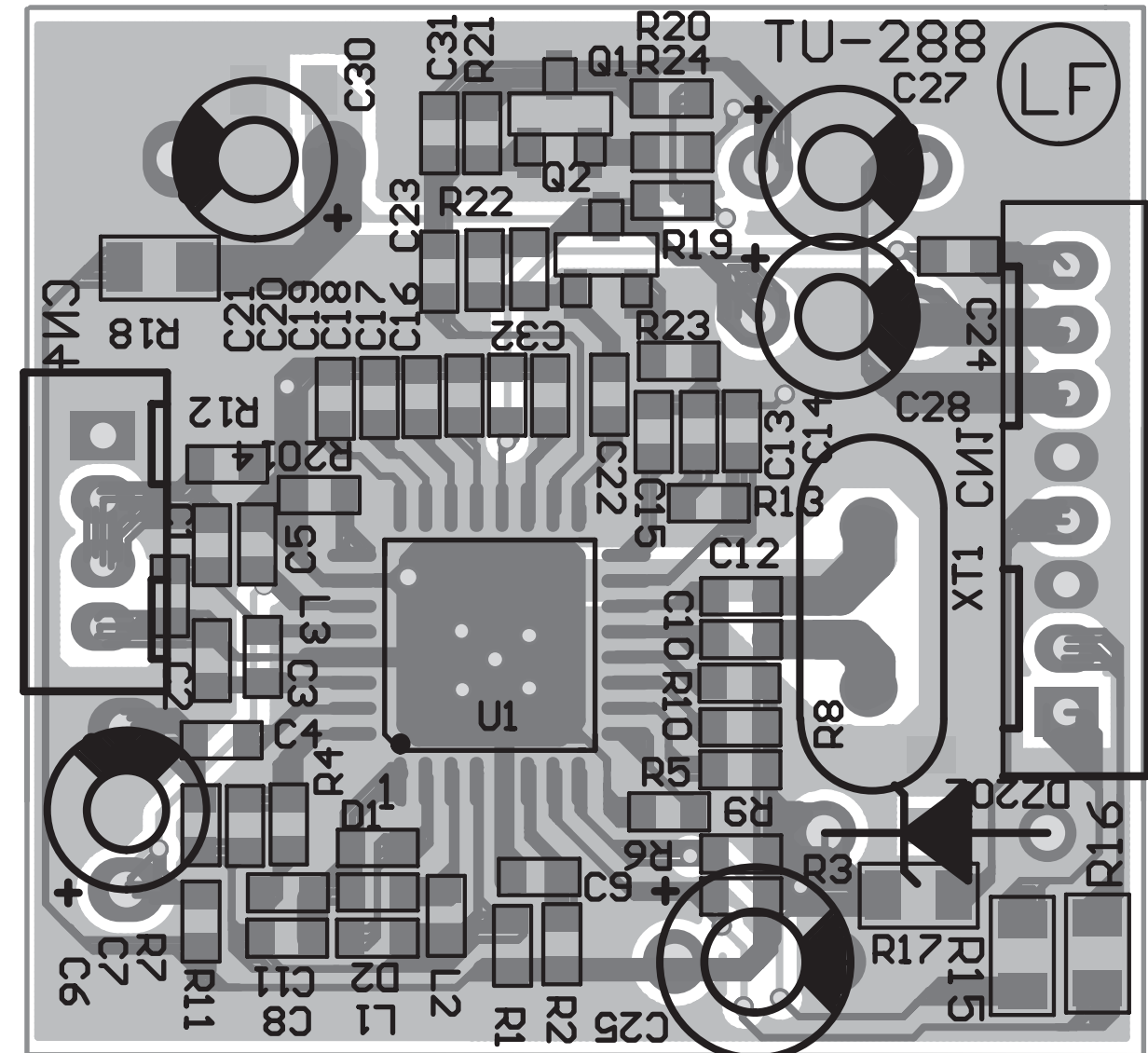



# CIRCUIT DIAGRAM

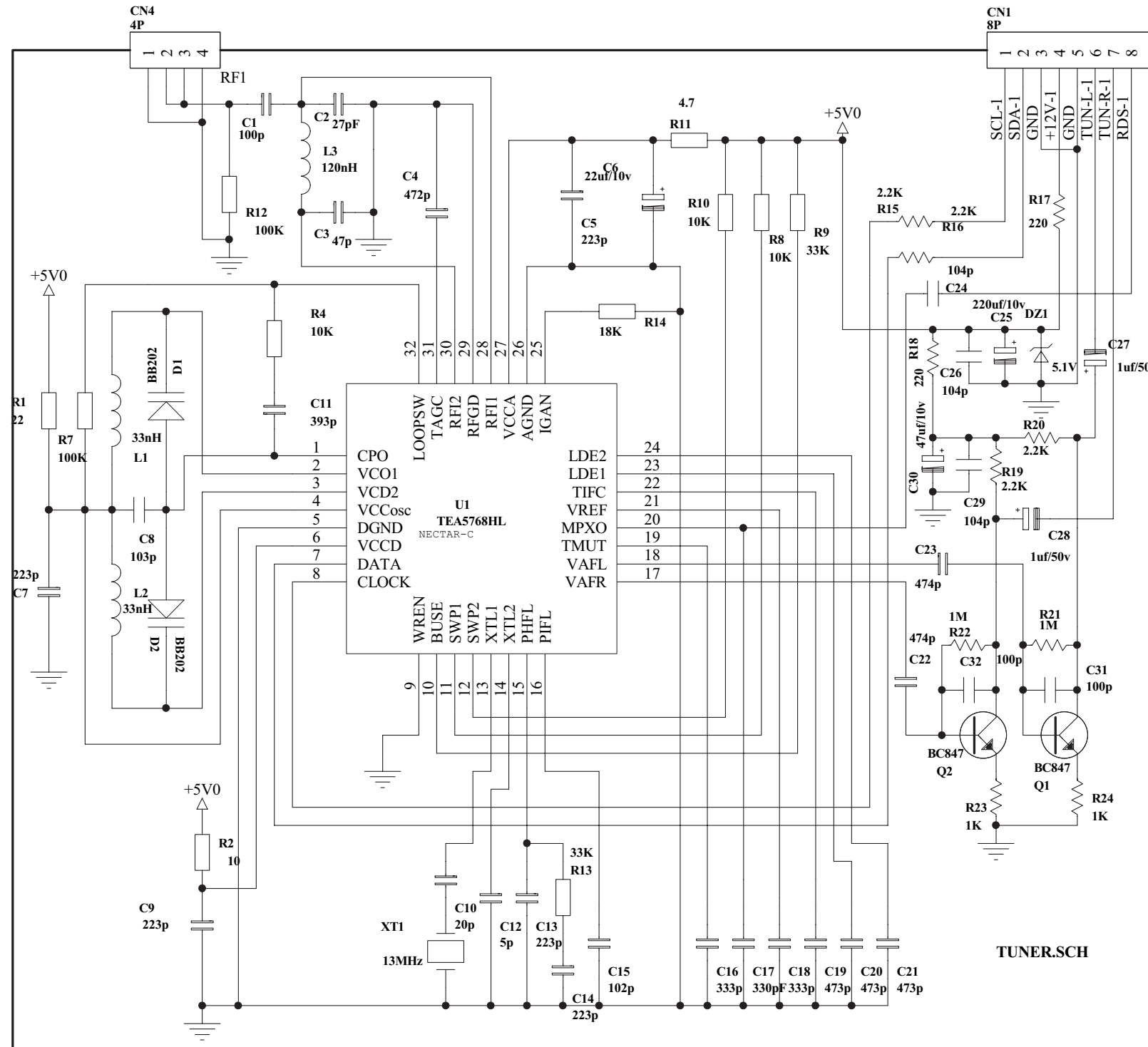

# POWER BOARD

**For Version 37, the board is not intended to be repaired on component level.  
Circuit Diagram and Printed Circuit Board drawings  
are published for orientation only.**

**In case of defects please replace the entire board.**

**The Power Board can be ordered with codenumber "9940 000 04865" for /37.**

# LAYOUT DIAGRAM - POWER BOARD

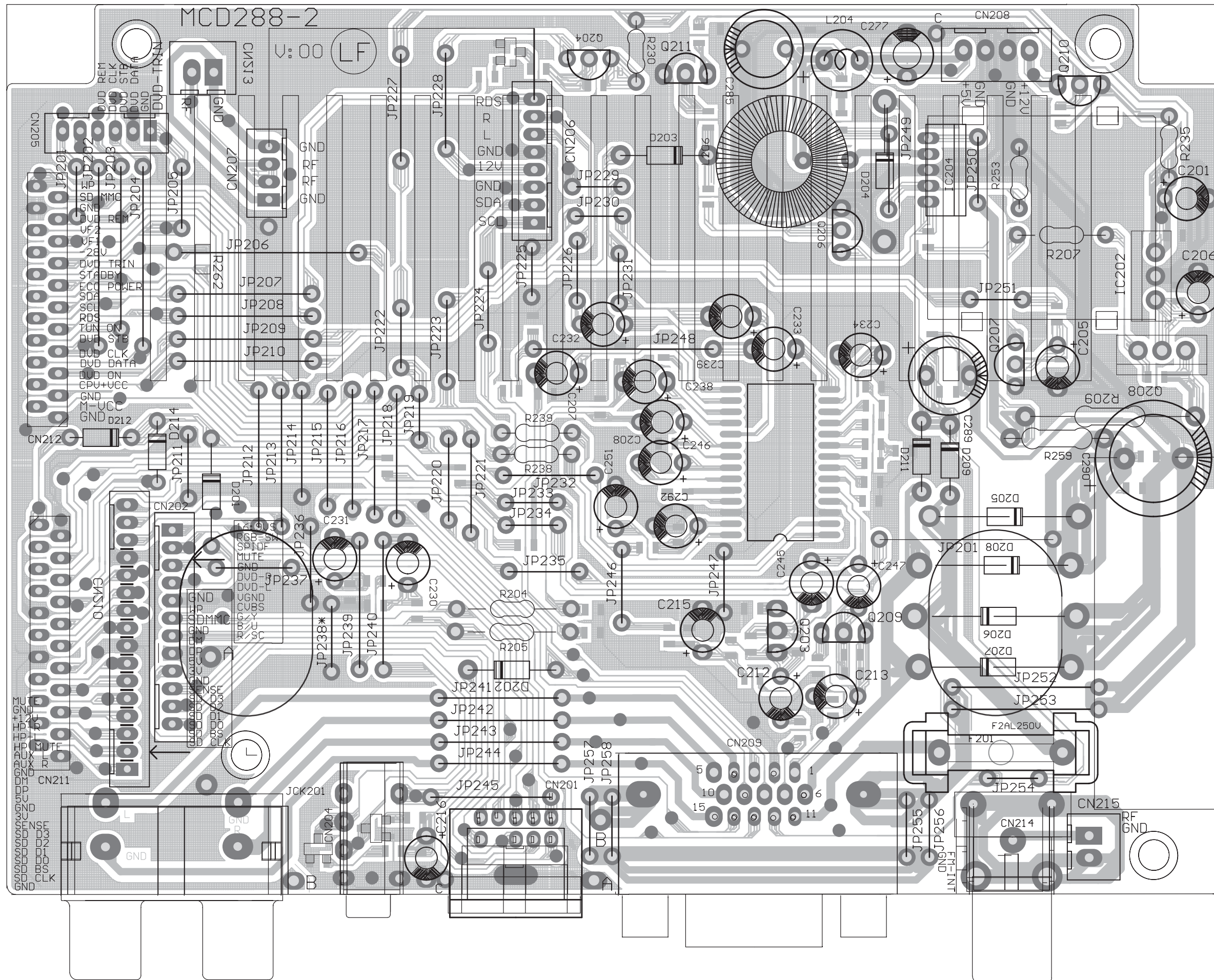

# CIRCUIT DIAGRAM - POWER BOARD

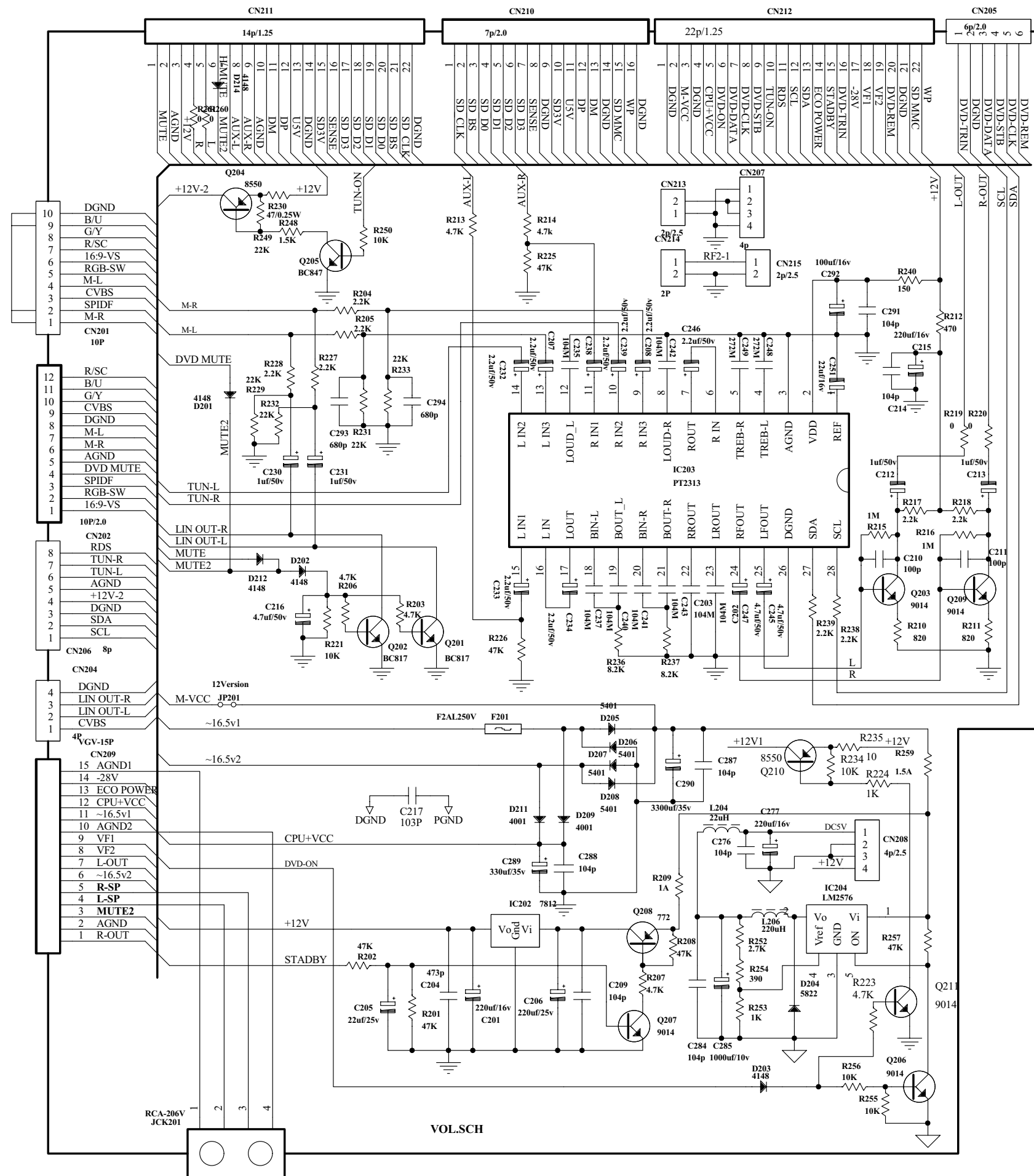

# WOOFER OUTPUT BOARD

For Version 37, the board is not intended to be repaired on component level.  
Circuit Diagram and Printed Circuit Board drawings  
are published for orientation only.

In case of defects please replace the entire board.

The Power Board can be ordered with codenumber "9940 000 04871" for /37.

## LAYOUT DIAGRAM - WOOFER TERMINAL BOARD (9940 000 04873)

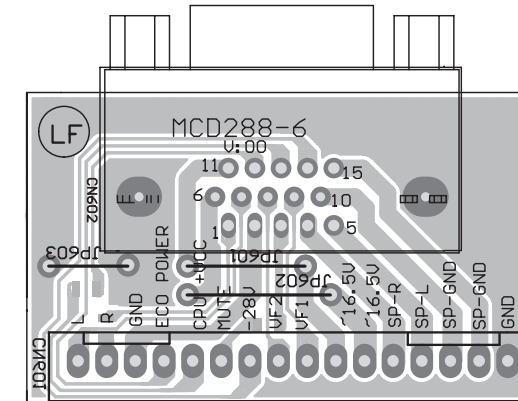

## LAYOUT DIAGRAM - WOOFER LAMP BOARD

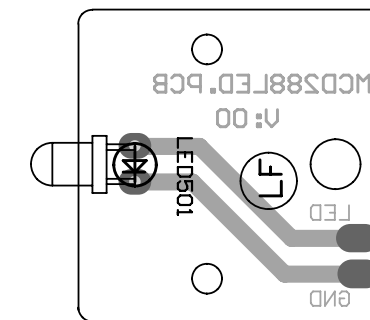

LAYOUT DIAGRAM - WOOFER OUTPUT BOARD

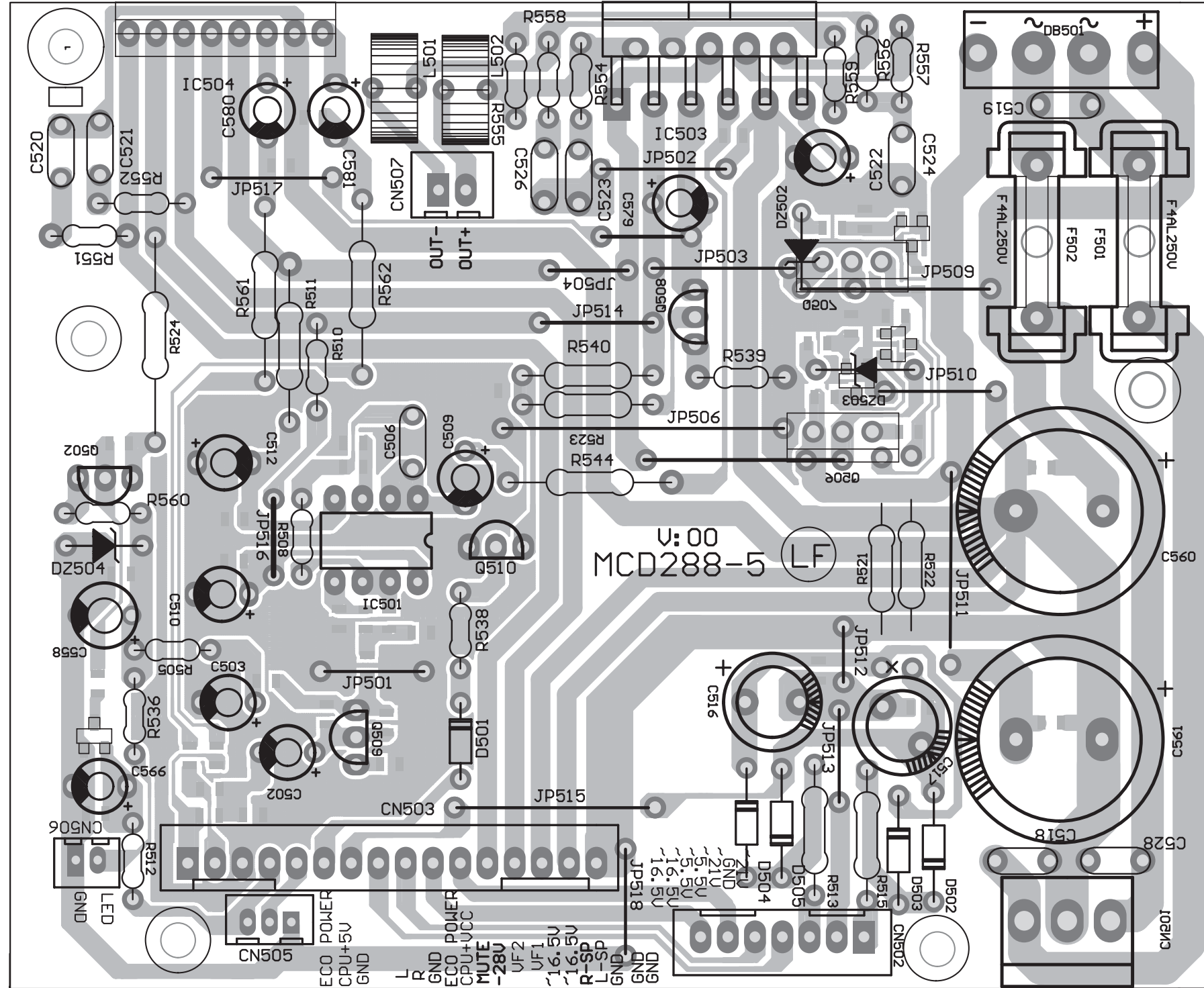

# CIRCUIT DIAGRAM - WOOFER OUTPUT BOARD

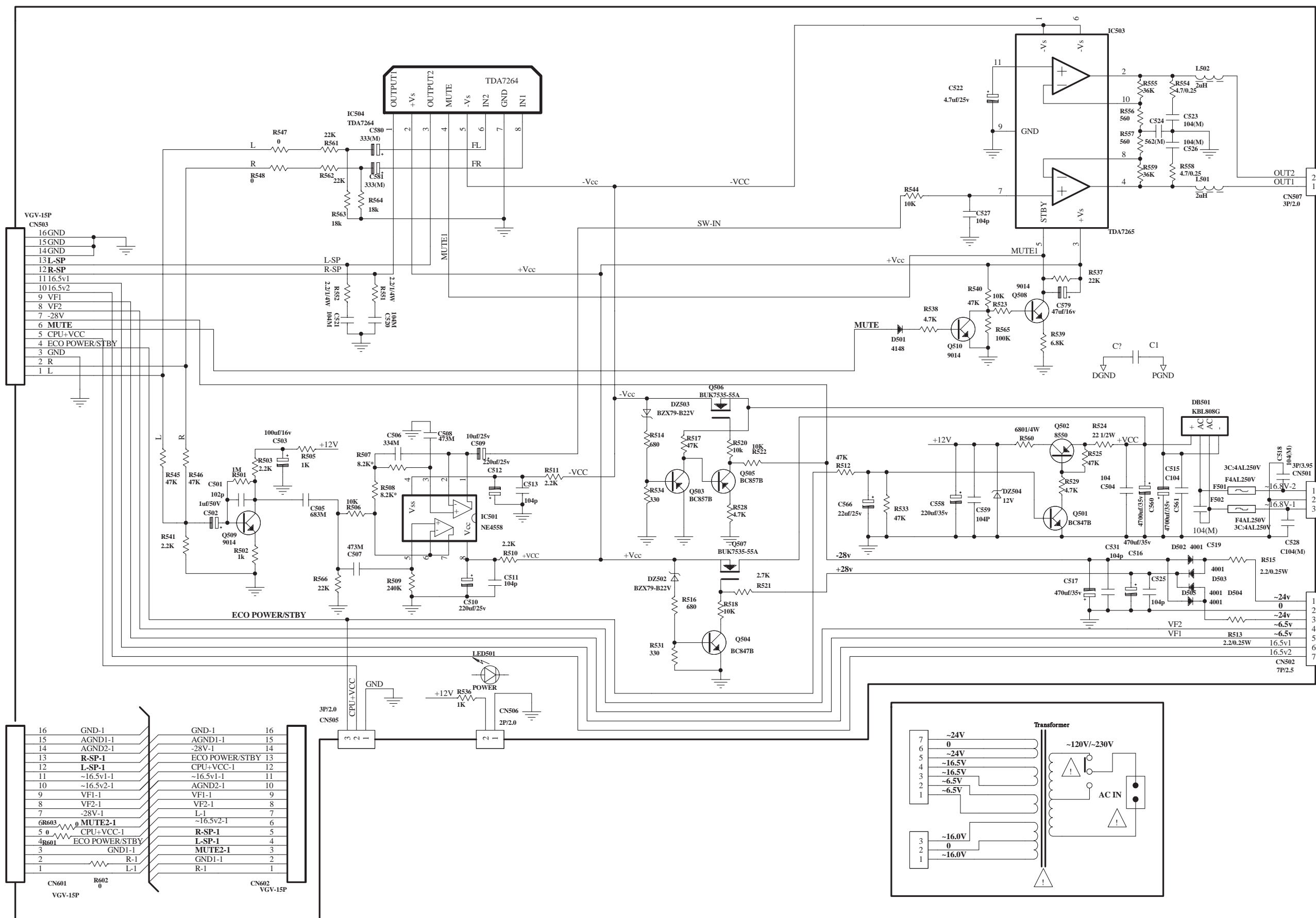

**ELECTRICAL PARTS LIST - WOOFER OUTPUT BOARD**

C506 9940 000 04971 NONINDUCTIVE CAP. 334J 100V  
C524 9940 000 04972 MYLAR CAP. 5600P 100V K-5  
C560 9940 000 04973 ELEC. CAP. 4700 $\mu$ F 35V  
C561 9940 000 04973 ELEC. CAP. 4700 $\mu$ F 35V  
DB1 9940 000 03502 THYRISTOR RS808

F501  $\Delta$  9940 000 03433 FUSE F6.3A L250V  
F502  $\Delta$  9940 000 03433 FUSE F6.3A L250V  
IC1301 9940 000 03767 IC TDA7265 STEREO POWER IC  
IC501 9940 000 04669 IC TL072  
IC504 9940 000 04976 IC TDA7264

Q502 9940 000 04974 TRANSISTOR 8550-C  
Q508 9940 000 02545 TRANSISTOR 9014C  
Q509 9940 000 02545 TRANSISTOR 9014C  
Q510 9940 000 02545 TRANSISTOR 9014C

**Note: Only these parts mentioned in the list are  
normal service parts.**



# SCART & VIDEO OUTPUT BOARD

For Version 37 and Version12, the board is not intended to be repaired on component level.  
Circuit Diagram and Printed Circuit Board drawings are published for orientation only.

In case of defects please replace the entire board.

The Video Output Board can be ordered with codenumber "9940 000 04874" for /37. The Scart Board can be ordered with codenumber "9940 000 04985" for /12

## LAYOUT DIAGRAM - VIDEO OUTPUT BOARD

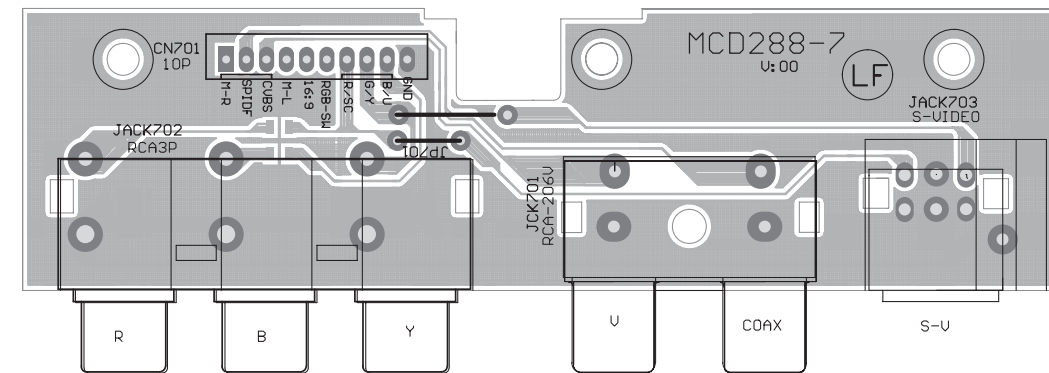

## CIRCUIT DIAGRAM - VIDEO BOARD

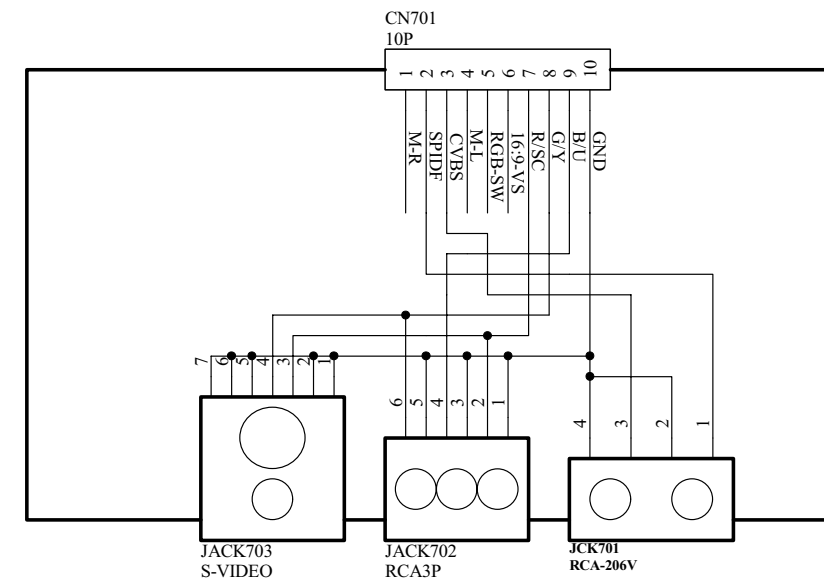

## LAYOUT DIAGRAM - SCART BOARD

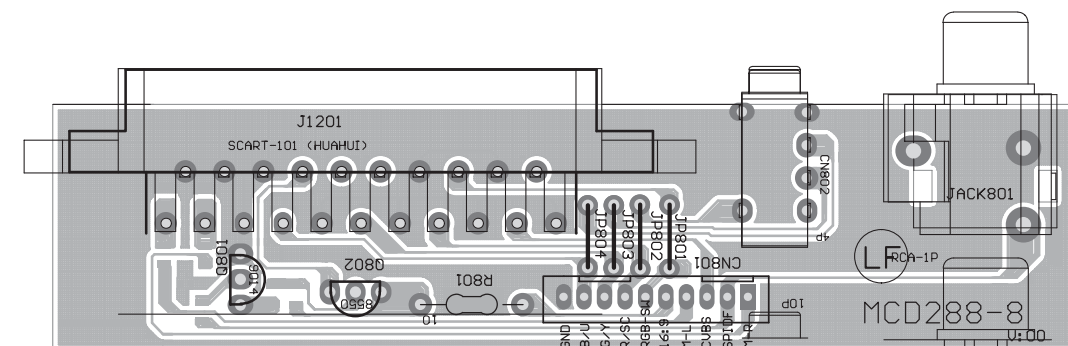

**SET MECHANICAL EXPLODED VIEW**

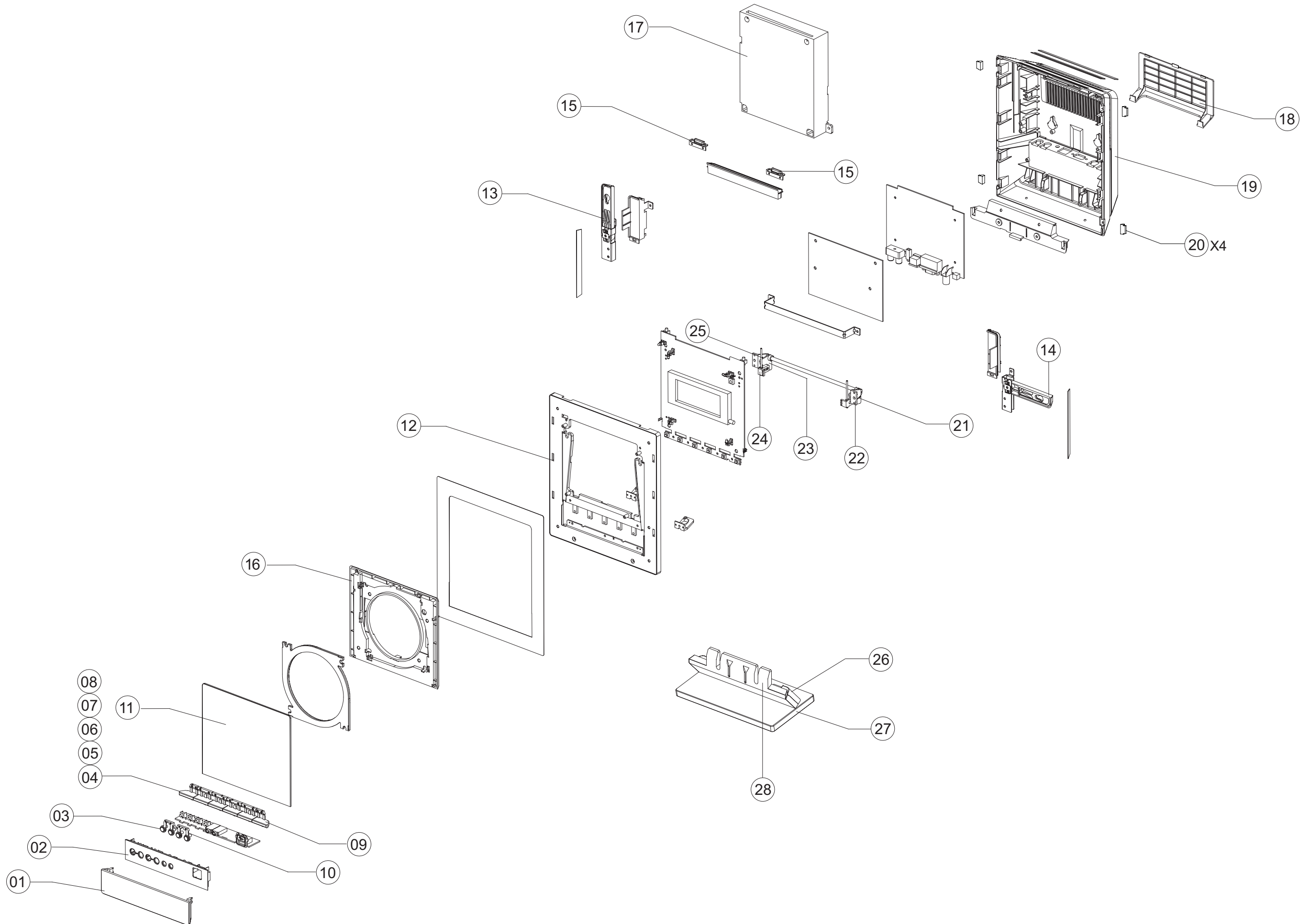

**MECHANICAL & ACCESSORIES PARTS LIST**

01	9940 000 04923	PUSH-DOOR /12/37	9940 000 04877	REMOTE CONTROL
01	9940 000 05011	PUSH-DOOR /93/98/55	9940 000 04881	WOOFER SPEAKER 8R 50W
02	9940 000 04912	ADDITIONAL-KEY-PANEL	9940 000 04885	D-SUB CABLE 15PIN
03	9940 000 04921	ADDITIONAL-KEY	9940 000 04886	AV CABLE (W/D3.5X1 & RCAX3)
04	9940 000 04914	FUNTION-KNOB(SOURCE)	9940 000 04887	9P/10P CONNECT CABLE 2M
05	9940 000 04915	FUNTION-KNOB(PLAY)	9940 000 04892	FM ANT. L=1.5M
06	9940 000 04916	FUNTION-KNOB(STOP)	9940 000 04925	FFC 14P 110 1.25
07	9940 000 04917	FUNTION-KNOB(PROGRAM)	9940 000 04926	FFC 22P 110 1.25
08	9940 000 04918	FUNTION-KNOB(VOLUME-)	9965 000 38886	LEFT SPEAKER BOX
09	9940 000 04919	FUNTION-KNOB(VOLUME+)	9965 000 38887	RIGHT SPEAKER BOX
10	9940 000 04903	ADDITIONAL-KEY-BRACKET	△ 9940 000 04987	TRASFO. EI-76 230V/50 /12
11	9940 000 04911	DISPLAY FRONT LENS	△ 9940 000 05009	TRASFO. 230V/50HZ /55/98
12	9940 000 04895	FRONT CABINET /37	△ 9940 000 05012	TRASFO. 230V/50HZ /93
12	9940 000 05004	FRONT CABINET /12/93/98/55	△ 9940 000 04878	TRASFO. 120V/60 /37
13	9940 000 04908	SPK ARM(L)	9940 000 04879	WOOFER SPEAKER BOX ASS'Y /37/55/93/98
14	9940 000 04909	SPK ARM(R)		
15	9940 000 04922	STANDBY/OPEN KNOB	9940 000 05013	WOOFER SPEAKER BOX ASS'Y/12
16	9940 000 04905	FRONT-LENS-BRACKET	△ 9940 000 03508	AC LINE CORD 1.8m /12/55/98
17	9965 100 00988	DVD MECHANISM KHM-313AAA	△ 9940 000 04888	AC LINE CORD 1.8m /37
18	9940 000 04899	OUTPUT-COVER	△ 9940 000 05166	AC LINE CORD 1.8m /93
			△ 9965 100 03642	AC LINE CORD 1.8m /05
19	9940 000 04896	BACK CABINET /37		
19	9940 000 05005	BACK CABINET /12/93/98	△ 9965 000 38997	AC LINE CORD 1.8m KS /61
20	9940 000 04924	SPK ORIENTATION RUBBER	△ 9940 000 04649	ECO POWER TRASFO. /12/37
21	9940 000 04894	SLIDE DOOR SPRING(R)	9965 000 38625	POWER PLUG ADAPTOR /05
22	9940 000 04904	PUSH DOOR BKT	9965 100 03638	SPEAKER BOX (R) ASS'Y /05
			9965 100 03639	SPEAKER BOX (L) ASS'Y /05
23	9940 000 04907	SWING ARM		
24	9940 000 04906	DOOR-LIP	△ 9965 100 00688	TRASFO. 220V/60 /61
25	9940 000 04893	SLIDE DOOR SPRING(L)		
26	9940 000 04898	FOOT-BACK-COVER		
27	9940 000 05422	FOOT		
28	9940 000 04897	FOOT-FRONT-COVER		
	9940 000 04882	SUBWOOFER FOOT BOTTOM		
	9940 000 04883	SUBWOOFER OUTPUT PAN		
	△ 9940 000 04884	AC SOCKET 2.5A/250V		
	9940 000 04901	SOCKET BOX BOTTOM COVER		
	9940 000 04902	SOCKET BOX TOP COVER		
	9940 000 04913	SOCKET BOX PANEL /37/55/93/98		
A1	9965 100 03645	VIDEO OUTPUT ASS'Y /12/05 (VIDEO BOX)		

**Note: Only these parts mentioned in the list are normal service parts.**

**ELECTRICAL PARTS LIST- MISCELLANEOUS**

9940 000 04862	ECO POWER PCB ASS'Y /12/37
9940 000 04865	POWER PCB ASS'Y
9965 100 17680	DISPLAY PCB ASS'Y /98
9965 200 00323	DISPLAY PCB ASS'Y /05/12
9965 100 00494	DISPLAY PCB ASS'Y /93/55/61
9940 000 04869	AMP KEY PCB ASS'Y
9940 000 04871	WOOFER OUTPUT BOARD ASS'Y
9940 000 04873	WOOFER TERMINAL BOARD ASS'Y
9940 000 04874	VIDEO OUTPUT PCB ASS'Y
9940 000 04875	TUNER BOARD ASSY
9965 100 03641	TUNER BOARD ASSY /12/05
9965 000 42750	DVD DECORDER BOARD ASS'Y /12/05
9965 000 42751	DVD DECORDER BOARD ASS'Y /37
9965 000 42752	DVD DECORDER BOARD ASS'Y /55
9965 000 42753	DVD DECORDER BOARD ASS'Y /93
9965 000 42754	DVD DECORDER BOARD ASS'Y /98
9940 000 04985	SCART BOARD ASS'Y /12
9965 100 03644	SCART BOARD ASS'Y /05
9965 100 00828	MCU PARTS ASS'Y /12/05
9965 100 00499	MCU PARTS ASS'Y /55/61

**Note: Only these parts mentioned in the list are normal service parts.**

**ELECTRICAL PARTS LIST**  
**- DISPLAY BOARD**

IC301	9940 000 04953	IC LM340T5 7805
IC302	9940 000 04957	CPU 3S9228
IC303	9940 000 04953	IC LM340T5 7805
IC304	9940 000 04951	IC 24C01A-SC27
IC305	9940 000 02539	IC PT6311
IC306	9940 000 02524	IC PT2309-S(L)
IC307	9940 000 03512	CHIP IC AC6811
IC308	9940 000 04956	IC TDA2579 /12
IC309	9940 000 04954	IC SA6208
LED301	9940 000 03437	LED 3B4SCB01
LED302	9940 000 03437	LED 3B4SCB01
LED303	9940 000 03437	LED 3B4SCB01
LED304	9940 000 03437	LED 3B4SCB01
LED305	9940 000 03437	LED 3B4SCB01
LED306	9940 000 03437	LED 3B4SCB01
LED307	9940 000 02537	LED (BLUE)
Q301	9940 000 02518	TRANSISTOR 8050C
Q302	9940 000 02519	TRANSISTOR 8550C
Q303	9940 000 02519	TRANSISTOR 8550C
Q304	9940 000 02518	TRANSISTOR 8050C
Q305	9940 000 02518	TRANSISTOR 8050C
Q306	9940 000 04949	TRANSISTOR 9014-C
Q307	9940 000 02518	TRANSISTOR 8050C
S301	9940 000 02542	IR SENSOR
SW305	9940 000 02543	LIGHT TOUCH SWITCH
SW306	9940 000 02543	LIGHT TOUCH SWITCH
SW307	9940 000 02543	LIGHT TOUCH SWITCH
SW308	9940 000 02543	LIGHT TOUCH SWITCH
SW309	9940 000 04964	LIGHT TOUCH SWITCH
SW310	9940 000 04964	LIGHT TOUCH SWITCH
SW311	9940 000 02543	LIGHT TOUCH SWITCH
SW312	9940 000 02543	LIGHT TOUCH SWITCH
X302	9940 000 03152	FILTER FREQ. 4.19MH
X303	9940 000 04962	CRYSTAL 4.332MHZ /12

**Note: Only these parts mentioned in the list are normal service parts.**

**ELECTRICAL PARTS LIST**  
**- POWER BOARD**

C290	9940 000 04932	ELE. CAP. 3300 $\mu$ F 35V
CN201	9940 000 04943	S-SOCKET DS-106
CN204	9940 000 04944	AV OUT SOCKET 4P
CN209	9940 000 04939	LEADING-OUT TER. 15P
CN214	9940 000 04941	FM OUTPUT SOCKET
F201	$\Delta$ 9940 000 02529	FUSE F2A L250V
F501	9940 000 03433	FUSE F6.3A L250V
F502	9940 000 03433	FUSE F6.3A L250V
IC203	9940 000 04936	IC PT2313
IC204	9940 000 04935	IC LM2576-ADJP
IC502	9940 000 04937	IC 7812
JCK201	9940 000 04942	2PIN RCA SOCKET
L206	9940 000 04931	FIXED INDUCTOR 220 $\mu$ H
Q203	9940 000 02545	TRANSISTOR 9014C
Q204	9940 000 02519	TRANSISTOR 8550C
Q206	9940 000 02545	TRANSISTOR 9014C
Q207	9940 000 02545	TRANSISTOR 9014C
Q208	9940 000 02517	TRANSISTOR 2SB772
Q209	9940 000 02545	TRANSISTOR 9014C
R259	$\Delta$ 9940 000 03412	FUSE F1.5A/125V

**Note: Only these parts mentioned in the list are normal service parts.**

**ELECTRICAL PARTS LIST**  
**- WOOFER OUTPUT BOARD**

C506	9940 000 04971	CAP. 334J 100V
C524	9940 000 04972	MYLAR CAP. 5600P 100V
C560	9940 000 04973	ELEC. CAP. 4700 $\mu$ F 35V
C561	9940 000 04973	ELEC. CAP. 4700 $\mu$ F 35V
DB1	9940 000 03502	THYRISTOR RS808
F501	△ 9940 000 03433	FUSE F6.3A L250V
F502	△ 9940 000 03433	FUSE F6.3A L250V
IC1301	9940 000 03767	IC TDA7265
IC501	9940 000 04669	IC TL072
IC504	9940 000 04976	IC TDA7264
Q502	9940 000 04974	TRANSISTOR 8550-C
Q508	9940 000 02545	TRANSISTOR 9014C
Q509	9940 000 02545	TRANSISTOR 9014C
Q510	9940 000 02545	TRANSISTOR 9014C

**Note: Only these parts mentioned in the list are normal service parts.**

**ELECTRICAL PARTS LIST**  
**- SCART BOARD (ONLY FOR /12)**

JCK801	9940 000 04983	RCA SOCKET AV-8.4-0.8B
JCK802	9940 000 03511	SCART 21P SOCKET
JCK803	9940 000 04944	AV OUT SOCKET 4P
Q801	9940 000 02545	TRANSISTOR 9014C
Q802	9940 000 02519	TRANSISTOR 8550C

**Note: Only these parts mentioned in the list are normal service parts.**

**ELECTRICAL PARTS LIST**  
**- ECO POWER BOARD(ONLY FOR /12/37)**

Q2201	9940 000 02518	TRANSISTOR 8050C
REL1201	9940 000 03509	RELAY 10A 240VAC/30VDC
	△ 9940 000 04649	ECO POWER TRASFO.

**Note: Only these parts mentioned in the list are normal service parts.**

**ELECTRICAL PARTS LIST**  
**- VIDEO OUTPUT BOARD(FOR /55/93/98)**

JACK701	9940 000 04979	RCA SOCKET 2P B/Y
JACK702	9940 000 02553	3PINS RCA SOCKET(R/B/G)
JACK703	9940 000 04982	S-VIDEO OUTPUT SOCKET

**Note: Only these parts mentioned in the list are normal service parts.**

***ELECTRICAL PARTS LIST***  
***- AMP KEY BOARD***

J104	9940 000 04966	HEADPHONE JACK D3.5
J105	9940 000 04967	AUX IN JACK CK3511
J106	9940 000 04968	USB JACK A-TYPE 4P
LED101	9940 000 02537	LED (BLUE)
LED102	9940 000 02537	LED (BLUE)
SW101	9940 000 04965	LIGHT TOUCH SW. KFC-05
SW102	9940 000 04965	LIGHT TOUCH SW. KFC-05
SW103	9940 000 04965	LIGHT TOUCH SW. KFC-05
SW104	9940 000 04965	LIGHT TOUCH SW. KFC-05

**Note: Only these parts mentioned in the list are normal service parts.**

***ELECTRICAL PARTS LIST***  
***- WOOFER TERMINAL BOARD***

CN602	9940 000 04939	LEADING-OUT TER. 15P
LED501	9940 000 03437	LED 3B4SCB01

**Note: Only these parts mentioned in the list are normal service parts.**

## REVISION LIST

### 1.0 Manual 3141 785 30800

Initial Service Manual released.

### 1.1 Manual 3141 785 30801

In this version, the content of Chapter 9 and Chapter 11 are corrected and updated.

Page 9-2: Layout Diagram-Woofer Output Board corrected.

Page 9-3: Circuit Diagram-Woofer Output Board corrected.

Page 9-4: Electrical Parts List added

Page 11-2: Mechanical & Accessories Parts List updated

### 1.2 Manual 3141 785 30802

In this version, Version /61 added.

Page 11-2: Mechanical & Accessories Parts List updated

### 1.3 Manual 3141 785 30803

In this version, Version /05 added.

Page 11-2: Mechanical & Accessories Parts List updated

### 1.4 Manual 3141 785 30804

In this version, DVD Decoder Board has been divided into 5 items as per separate version.

Page 11-2: Mechanical & Accessories Parts List updated

### 1.5 Manual 3141 785 30805

In this version,

Page 11-2: Mechanical & Accessories Parts List updated.

Add:

9965 100 17680 DISPLAY PCB ASS'Y /98

9965 200 00323 DISPLAY PCB ASS'Y /05/12

9965 100 00494 DISPLAY PCB ASS'Y /93/55/61

Delete:

9940 000 04868 DISPLAY PCB ASS'Y

### 1.6 Manual 3141 785 30806

In this version,

Page 11-2: Mechanical & Accessories Parts List updated.

Add:

A1 9965 100 03645 VIDEO OUTPUT ASS'Y /12/05 (VIDEO BOX)